

PRICE 10 CENTS

MAY, 1908

Vol. I.

No. 2.

MODERN ELECTRICS

Published by MODERN ELECTRICS PUBLICATION, 84 West Broadway, New York, N. Y.

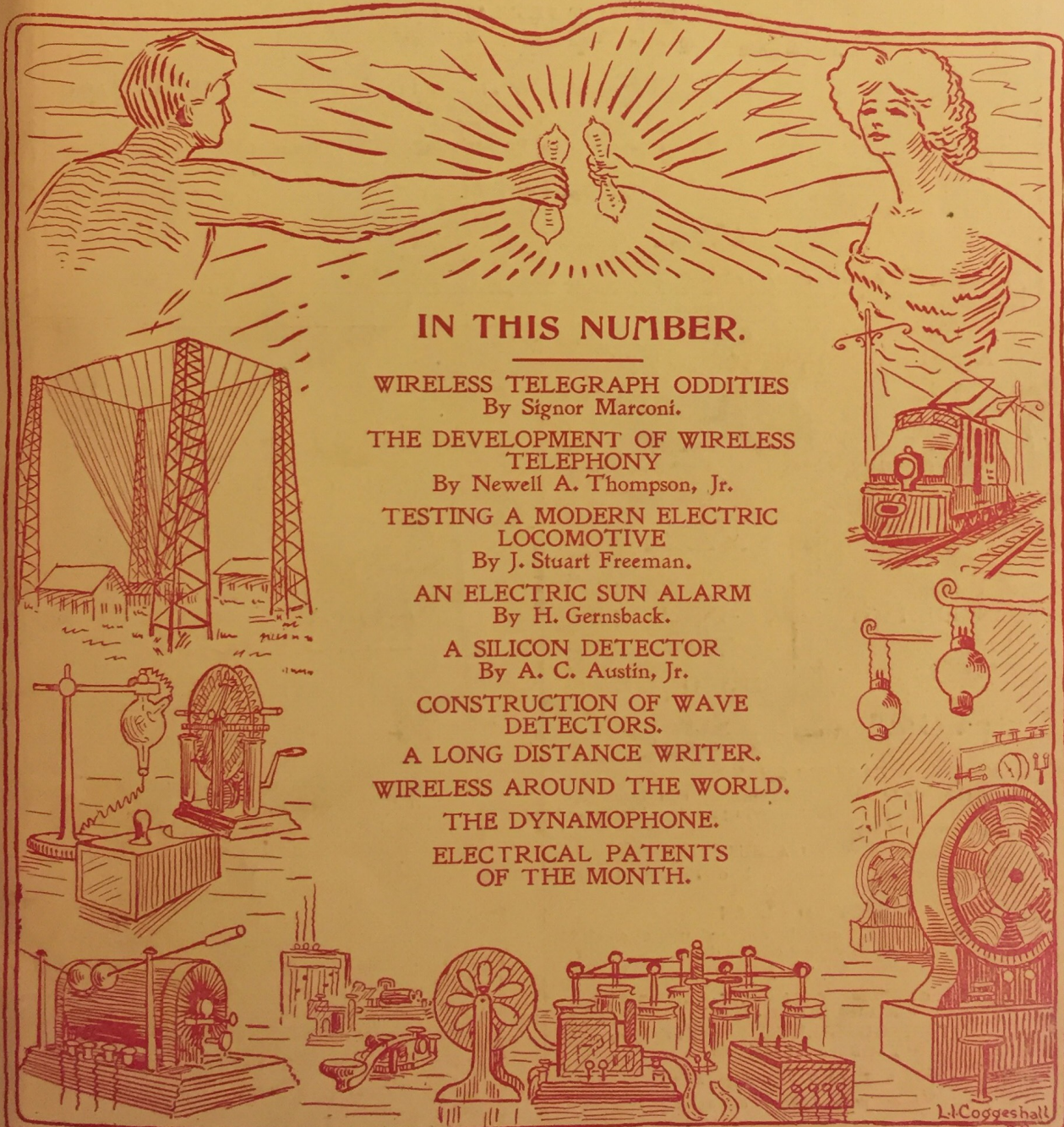

The illustration depicts a man on the left and a woman on the right, both holding glowing light bulbs. The scene is set against a background of radiating lines, suggesting light or energy. Below this central image, there are several smaller illustrations of electrical equipment, including a large tower structure, a dynamo, a fan, and various electrical components. The artist's signature 'L. Coggeshall' is visible in the bottom right corner of the illustration.

IN THIS NUMBER.

- WIRELESS TELEGRAPH ODDITIES
By Signor Marconi.
- THE DEVELOPMENT OF WIRELESS
TELEPHONY
By Newell A. Thompson, Jr.
- TESTING A MODERN ELECTRIC
LOCOMOTIVE
By J. Stuart Freeman.
- AN ELECTRIC SUN ALARM
By H. Gernsback.
- A SILICON DETECTOR
By A. C. Austin, Jr.
- CONSTRUCTION OF WAVE
DETECTORS.
- A LONG DISTANCE WRITER.
- WIRELESS AROUND THE WORLD.
- THE DYNAMOPHONE.
- ELECTRICAL PATENTS
OF THE MONTH.

"The Electrical Magazine for Everybody"

OUR NEW PREMIUMS

MODERN ELECTRICS can only grow by having a very large circulation. In order to obtain same we offer the premiums listed below. Anybody who knows the value of these articles will understand how much we sacrifice in order to get a large amount of new subscribers. The offer is good only for this month: order at once as only a limited amount of premiums is on hand.



TUBULAR SEARCHLIGHT

Finest imported make. Warranted to give 8000 flashes. Sells everywhere for \$1.50 and is cheap at that. Has metal filament lamp, bulls eye lens, silver reflector, etc.
Given for two subscriptions

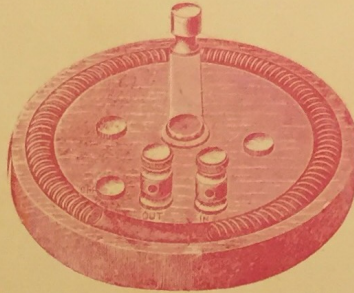

RHEOSTAT REGULATOR

10 ohms guaranteed. Reduces current gradually, not by steps. Dims down small incandescent lamps, controls speed of small motors, for electroplating, etc., etc. Sold everywhere for 75 cents.
Given for one new Subscription.

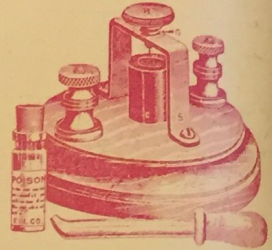

ELECTRO-LYTIC DETECTOR

Latest improved type. Homogenous carbon cup. Micrometer, thumb screw carrying fine Wollaston wire 0.0001 inch diameter. Will catch messages from 500-800 miles. Most sensitive type ever gotten up. Sells everywhere for \$2.00.
Given for three subscriptions

Modern Electrics Publication

84 West Broadway, New York City

A SAFETY RAZOR SENSATION

"Shrp Shavr"

Price **75c.** Or **40-2c.**
In Cash **5** Stamps

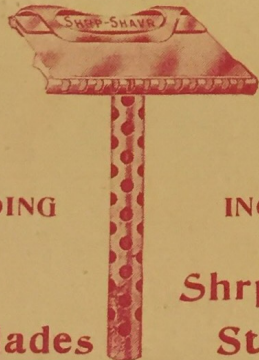

INCLUDING **5** INCLUDING
Extra Blades **Shrp Shavr**
Stropper

EASY TO SHAVE

Because the Blade is the best money can buy. The Frame is made at the proper shaving angle which gives the best result and insures safety.

EASY TO ADJUST

The Blade slides into the right side of Frame. Is held rigid. Cannot work loose or fall out.

EASY TO CLEAN

The Frame is made of highly finished nickel steel, in one piece; can be readily washed and dried.

EASY TO BUY

75c A Sensational Price; Razor, 5 Extra **75c**
Blades and Stropper
THE COMPLETE OUTFIT
"The Razor at the Top"

WE GUARANTEE SATISFACTION OR MONEY REFUNDED

You can make money as our agent

Clemens Schroeder Co. 320 1/2 BROADWAY
NEW YORK

When writing please mention "Modern Electrics."



ELECTRICITY Girdles the Globe

It is the giant force of the Century. Electricity offers larger rewards to PRACTICALLY trained followers than any of the other professions.

Learn it and you have mastered the most fascinating and BEST PAID calling of to-day.

Our school, the most thoroughly equipped in the United States, teaches PRACTICAL ELECTRICITY in all its branches, and nothing else. Individual instruction, day or evening by skilled teachers.

Write for 64 p. illustrated book. It's free.

The New York Electrical Trade School
39 1/2 West 17th Street, New York
No connection with any other School or Institute.

When writing please mention "Modern Electrics."

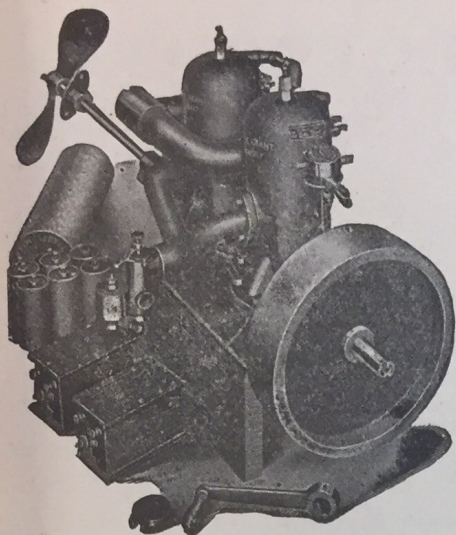

\$49 Little Giant
 3 to 5 H. P.
 (BARE) **GASOLINE MOTORS**

Guaranteed for one year.

Our Free Catalog C12 is worth your having.

Send 10 cents in stamps for our book "Ignition, Vaporization, Installation and Operation of a Motor."

UNITED MFG. CO., Dept. Z, Detroit, Mich.

When writing please mention "Modern Electrics."

"LIVE WIRE" GOODS AT "LIVE WIRE" PRICES

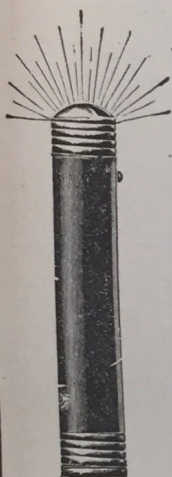

TUBULAR SEARCH LIGHT

Without question the best on the market to-day. Guaranteed for 10,000 flashes. Intense white light. Safe, durable; you can light it in a powder keg.

Price this month only

70 Cents

By mail 18 cents extra.

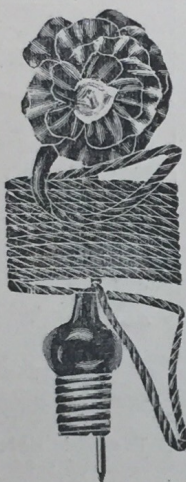

ELECTRIC SCARFPIN

Most fascinating novelty on earth. Comes in different designs, such as Owl's Head, Horseshoe, Crescent, Heart shape, etc. Works with any flashlight, which is carried in pocket. To operate, simply press button. Greatest thing for boys, clubs, societies, etc. Complete **45 Cents**. By mail 5 cents extra. Flashlight case with battery (no lamp) to operate above **39 Cents**. By mail 6 cents extra.

The "New York" Motor

Cheapest and best small motor ever produced. A "hummer" in every respect. Runs 2000 revolut. p. M. on one dry cell. Develops a surprising amount of power. By reversing magnet it will run in different direction. The slickest motor ever produced. Price, **45 Cents**. By mail 5c extra.

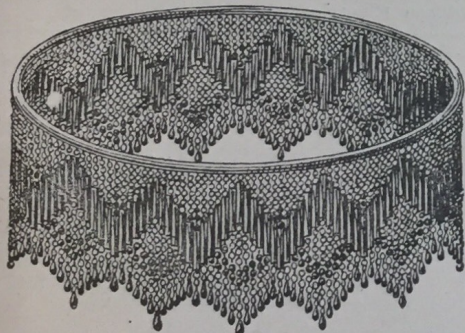
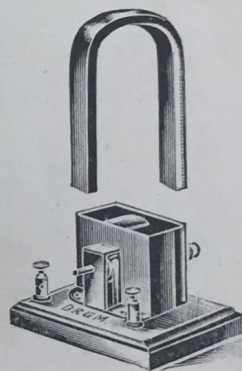

GLASS BEAD FRINGE RINGS

Fits all gas or oil lamps. Makes any room look cosy and cheerful. Red or green 10 in. or 12 in. wide. Price, **\$1.25** by mail. Fancy designs (see cut) **\$2.00** by mail. As a gift nothing can be more appreciated.

ORDER TO-DAY.



IMPORTED FLASHLIGHT LAMP

Has lens blown in top to give greater amount of light. There may be cheaper lamps, but not better ones than this one. Price, **12 Cents**. By mail 2 cents extra

Complete line of Electric Pocket Flash Lights and Batteries, Electrical Novelties, miniature Lights of every description, Geissler Tubes, Medical Coils, etc.

Send 2 Cents for Catalog.

Alfred Wolff & Co.

47 VESEY ST.

NEW YORK CITY



\$1.50 FLASHLIGHT 59c

Agents, here is your chance.

The ever-ready Electric Flashlight all complete, retails at \$1.50 Gives 3 000 flashes. Each 59c Postage extra 10c. Catalog free

JOHN NELSON ELECTRICAL CO.
 Dept. Z. Kewanee, Ill.

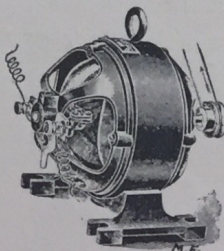

Knapp Electric Power Plant

Type "S" Dynamo. Semi-Enclosed. 6 Volts, 4 Amperes. All up-to-date features 1 in. pulley for belting to any driving power. Will run Motors, Electric Railways, Charge Storage Cells, Electro-plate, etc. **PRICE, \$5.00**. Shipping weight, 6 1/2 lbs. Hand Driving Device additional \$5.00; Shipping weight, 16 lbs. Noiseless. Easy to operate. Send 2c. stamp for 32-page Catalog.

Knapp Electric & Novelty Co., 517 W. 51st St., New York

When writing please mention "Modern Electrics."

When writing please mention "Modern Electrics."

"Modern Electrics" guarantees the reliability of its advertisers.

SEND FOR IT

10c. WIRELESS CODES Blue Print showing Morse, Continental and Navy Codes

A. C. AUSTIN, Jr., HASBROUCK HEIGHTS, N. J.

YOU NEED IT

When writing please mention "Modern Electrics."

WANT A GOOD ELECTRICAL BOOK ?

Look Over This List. Price 10 Cents Each

- | | |
|-----------------------------|----------------------------|
| 1 Dynamo | 15 Toy Motor |
| 2 Telephone | 16 Electric Bell |
| 3 Motor | 17 Telegraph Instrument |
| 4 Storage Battery | 18 Wind Armatures |
| 5 Wimsnurst Machine | 19 Wind Field Magnets |
| 6 Magneto | 20 Ammeter |
| 7 Medical Coil | 21 Thermostat |
| 8 Pocket Accumulator | 22 Motor Rotation |
| 9 Plunge Battery | 23 Electric Soldering Iron |
| 10 Voltmeter | 24 Electric Heater |
| 11 Galvanometer | 25 Electric Furnace |
| 12 Hand Dynamo | 26 Hand Feed Arc Lamp |
| 13 Tapping Machine | 27 Jump Spark Coil |
| 14 1/2 H.P. Dynamo or Motor | 28 Rheostat |

Recent 25c. Books 101 Transformer 103 Condenser

New Bulletin on Rough Castings for Dynamos and Motors will be sent with any of above. Also Catalog of Books on Electricity and Mechaucis

BUBIER PUBLISHING COMPANY, 84 LYNN, MASS.

When writing please mention "Modern Electrics."

FREE
TWO BOOKS:
68-Page
"Inventor's Guide"
—AND—
"Fortunes in Patents"
"What and How
to Invent"

PATENTS GUARANTEED

Protect Your Idea
SPECIAL OFFER: Send sketches or model and description of invention for FREE SEARCH of Patent Office Records and Reports as to patentability. You will save TIME and MONEY. Highest references.

E. E. VROOMAN Regis't'd Patent Attorney
Box 60z Washington, D.C.

REFERENCES:

- American National Bank Washington, D. C.
- Little Giant Hay Press Dallas, Texas
- Gray Lithograph Co. New York City, N. Y.

When writing please mention "Modern Electrics."

Southern Pacific Telegraph School

Trains young men for operators—positions guaranteed and tuition refunded. Salaries \$75 to \$90 month. Address,

SCHOOL OF TELEGRAPHY, 306 z 12th St., Oakland

When writing please mention "Modern Electrics."

COYNE TRADE SCHOOL

ELECTRICITY, PLUMBING, PLASTERING
BRICKLAYING.

DAY AND NIGHT. NO BOOKS.

Free Catalogue. Scholars 15 to 50 years old.

Enter Now. 236 8th St. San Francisco

When writing please mention "Modern Electrics."

If you wish to sell or exchange anything, do not fail to advertise in classified "ad's" (see page 73.) 12,000 people read this paper.

When writing please mention "Modern Electrics."

ELECTRICITY

Bliss Electrical School is the oldest and best school in the world teaching ELECTRICITY exclusively. Course complete in One Year

Students actually construct Dynamos, Motors and Electrical Instruments. Graduates hold good positions throughout the world. Sixteenth year opens September 23. Send for Catalog to BLISS ELECTRICAL SCHOOL, 213 1/2 G Street, Northwest, Washington, D. C.

When writing please mention "Modern Electrics"

Practical Telegraphy

Taught by experts at my school. My institution on one graduating qualified operators. Thorough practical, copyright methods. Good positions secured. Living expenses earned while learning. Easy payments. Correspondence course if desired. Catalog FREE.

Geo M. Dodge, Pres.

Dodge's Institute of Telegraphy, 6 Eighth Street, VALPARAISO, IND. Established 1880

When writing please mention "Modern Electrics"

MODELS

Experimental and Electrical Work

Inventions Designed and Perfected. High Class Exhibit and Working Models. Model Supplies. Patterns, Dies, Tools, Gear. Write for Catalog.

WAGNER MODEL WORKS, OFFICE & WORKS 19 MOHAWK ST., CHICAGO

When writing please mention "Modern Electrics."

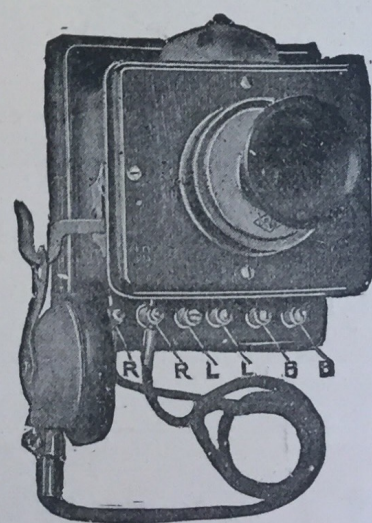

PRIVATE TELEPHONE SET.

Equal in operation to the best. Do not compare with cheap 'phonos' which in the end are the most expensive. Complete pair per cut, \$4. Remit by money order. Complete line of Electrical Novelties, General Electrical and Automobile Supplies. Send for FREE Catalog. "We never disappoint."

Chas. W. Levering 181 Greenwich New York City

When writing please mention "Modern Electrics"

If you wish to buy something and don't know where to get it, ask

Modern Electrics

All information given free of charge

When writing please mention "Modern Electrics"

MODERN ELECTRICS

Vol. I.

MAY, 1908.

No. 2.

Testing a Modern Electric Locomotive

BY J. STUART FREEMAN.



The Famous "6000."

In the eighty years of the development of locomotives for long-distance transportation, only a dozen years or so passed since the electric locomotive has been in the field. But fourteen years ago no such thing had been heard of, and, while the steam locomotive of today is the result of three-quarters of a century of invention and improvement, the present perfection of the electric locomotive has been reached after only a decade of experimental and research work. For some of us who are more or less familiar with them the novelty has begun to wear off, but there are hundreds of engineers who would place great value upon a trip on one of them. For those of my readers who are among the less fortunate, I will attempt to describe a trip on one of these modern "Rail Eaters."

We board an electric car at Schenectady, N. Y., the home of the electric engine, and go west through the Mohawk Valley. We have to ride but three miles when our car, running parallel to the New York Central tracks, gets abreast of the eastern end of the well-known and much-feared third rail, with its familiar signs at short intervals, reading:

DANGER.
LIVE THIRD RAIL.

Here we see one of those silent, mysterious bulks of iron, standing quietly and with no puffing and blowing, as in the case of a steam engine, impatient to be off, but with a majestic silence, telling us of vast power pent up within it and but temporarily subdued.



No. 3424 Making 79 Miles Per Hour.

Continuing up the valley, we look out of the window, and are allowed but a few seconds in which to catch a glimpse of the once still engine now devouring the track on which it runs at an enormous rate of speed, and soon becoming invisible in the distance, although we are running in the same direction at 50 miles per hour. Soon, however, we ar-

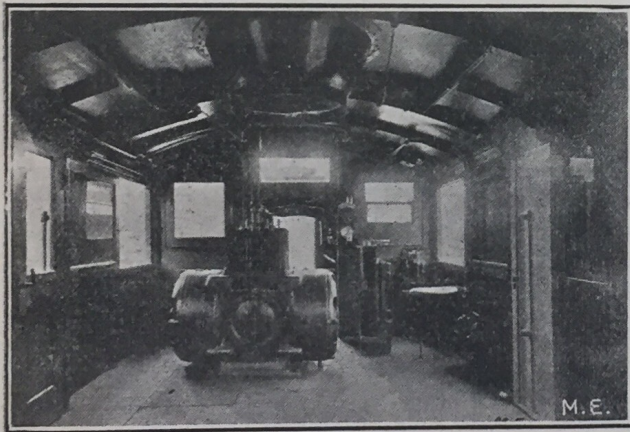

Interior of No 3424.

rive at Wyatt's crossing, the location of the sub-station and barn. Here we await the return of the engine, and in the meantime wander about the station.

High up on one side of the wall the 33,000 volt lines enter from the outside, and immediately below are the curiously shaped lightning arresters and the long, slim main switches. Down on the floor are a set of transformers which reduce the alternating current of 33,000 volts to a much lower potential. From these the current runs to the rotary converter,

shown in the illustration, which, in turn gives off a direct current of but 660 volts, which current is supplied to the third rail, paralleling the track outside.

But the engine is awaiting us now having been stopped by one of the employees, so we must hurry aboard. First however, the conductor must take our pass so as to protect himself in case anything should happen to us. He finds all is right and signals to go ahead. The bell clangs forth a few strokes and the "engineer," who is a motorman, slowly opens his "throttle." Slowly, steadily and with almost no sound, we begin to move. The motorman does not hold his lever on the first notch, but quickly pulls it over the entire first set, of which there are three, and the motors continue to accelerate perfectly smooth until near their limit of speed under that set, where he gives them additional "juice."

Starting from the western end, we have a straight stretch of three-quarters of a mile, at the end of which are several sharp, double curves. Along here he is not allowed to exceed a speed of 65 miles per hour for safety's sake. This is rather fast traveling, after never having gone faster than about 60 miles per hour, and we wonder at the ease with which our steed takes the curve leaning far over to the inside so that when standing erect we are 10 degrees from the perpendicular. At the end of the curve she rights herself and slowly leans in the opposite direction on going around the next curve.

(Continued on page 72.)

A Silicon Detector

By A. C. AUSTIN, JR.

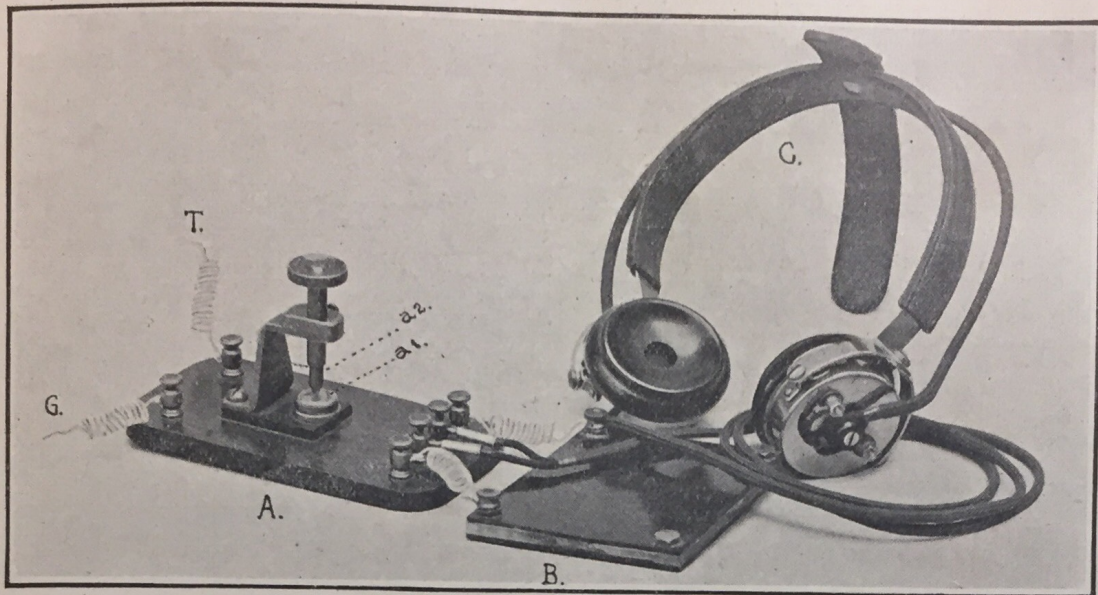

About a year ago the writer had the opportunity of examining a Pickhardt Silicon Detector, and after listening to it in operation, decided to build one himself. The operator, a friend, explained the action of the detector in detail, saying in part there were no batteries to run down, that the adjustment was very easy, and when once adjusted it could be depended upon not to get out of order, and that the connections were very simple.

From his explanation the instrument (hereinafter described) was built, at a cost of about \$3.00, and was afterward tested on one of the Fall River Line steamers, where it proved to be so sensitive that wireless telephone could be heard with it.

A silicon detector, when used with telephone receivers wound to 1,000 or 2,000 ohms resistance, is as sensitive, if not more so, than the electrolytic detector, and it does not get out of adjustment easily. However, telephones wound to a high resistance must be used, for without such telephones the advantages are not so appreciable.

The writer has experimented with a number of detectors, among them the Carborundum, of which a description will be given in a later issue, the carbon-mercury, microphonic, etc., but finds them all faulty at times, while the silicon detector seems to be the most constant, sensitive and satisfactory.

The illustration herewith shows all the receiving apparatus, except the tuning coil, "A" being the detector proper, "a 1" is the silicon and "a 2" the brass point resting thereon, "B" is the condenser and "C" the telephone receivers. "T" are leads to the tuning coil, thence to the aerial switch and aerial, and "G" through the same switch to the ground.

The materials for this detector may be obtained from any good supply or importing house, and directions for construction are as follows:

Procure a wooden base such as is used for pony relays, same to be of the dimensions as shown in Fig. 1; bore 9 holes, as per Fig. 1, large enough to accommodate $8/32$ " screws, countersinking them $3/16$ " so as to accommodate washers and screw heads, and then cut the grooves for the connections, making them of sufficient depth to allow the instrument to set flat when completed. There must also be six small binding posts to set in holes "a," "b," "c," "d," "e" and "f."

Procure a piece of hard rubber $1/8$ " thick and trim to size $1 1/8$ " x $1 27/32$ " and bore holes as per Fig. 2, "g" and "h" to be large enough to accommodate $8/32$ " screws. Also two round-head brass screws $8/32$ " thread, about $3/4$ " long.

Make a piece of brass of the dimensions shown in Fig. 3. Get three nuts $8/32$ " thread and three washers to fit the three last-mentioned parts.

FROM MODERN ELECTRICS, MAY 1908

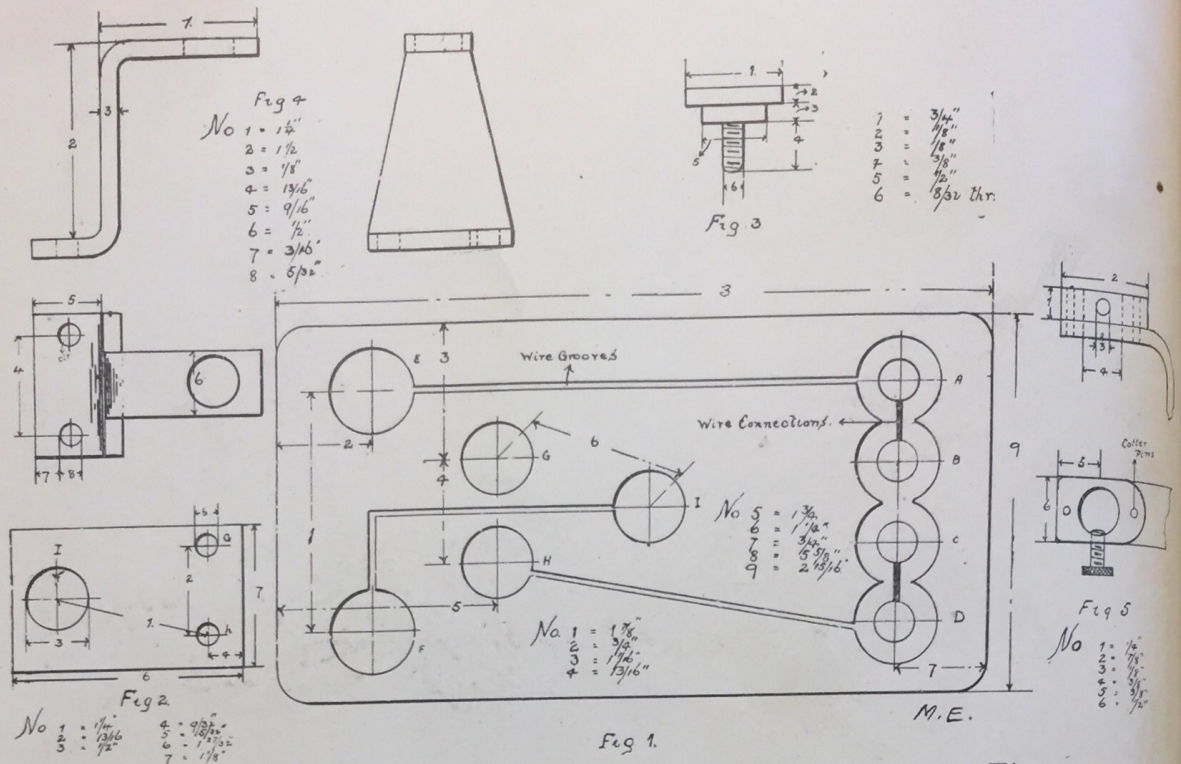

Procure a piece of brass $3\frac{1}{2}$ " long (this allows for wastage), $\frac{1}{8}$ " thick, $1\frac{1}{8}$ " wide at one end and $\frac{1}{2}$ " wide at the other, and make up as per Fig. 4.

Also another piece of brass $\frac{1}{4}$ " x $\frac{1}{2}$ " x $\frac{7}{8}$ " and by pinning and soldering or brazing, fasten to the upper side of the $1\frac{1}{4}$ " arm of the support just mentioned, rounding the corners to make a nice ap-

pearance, as shown by Fig. 5.

Bore a hole $\frac{3}{8}$ " in diameter, as shown in Fig. 5, through the boss, and then through the side of same, as shown, put a small hole, threaded with any convenient small thread, and put a set screw in same so as to clamp the adjustable brass point which rests on the silicon.

(To be continued.)

A New Battery

The accompanying engraving is not a new-fangled bomb, but a harmless though powerful new battery. It is a German invention and the construction is in every respect well carried through.

The inventor seems to think that a wet cell is better than a dry one—a belief which we share with him.

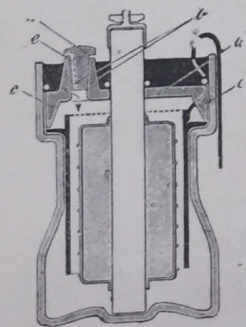

In the April issue, under "Recharging Dry Cells," we showed why such cells are not effective, and as will be seen the German constructor has produced something real logical.

The odd shape of the glass container

keeps the zinc cylinder from shifting; the depolarizer comes quite close to the zinc (up to $\frac{3}{16}$ ") to reduce the internal resistance. It is therefore not surprising that a cell being only 6" high and 3" in diameter furnishes about 40 amperes in short circuit. The depolarizer used is a mixture of oxide of manganese (98%) and finest flake graphite.

When exhausted the vent e, is simply opened and the cell can be rinsed out with boiling water; refilled with a solution of sal-ammoniac and chloride of zinc the battery will work again as well as when new.

The cell comes with the exciting salt filled in container and all one has to do is to fill it up with clean water, when immediately afterwards it is ready for use.

The vent stopper also presents a new feature. It has a fine channel at the point where it touches the wall of the hole; this channel is provided to let off the gases which are generated in any battery.

The Dynamophone

BY H. GERNSBACK.

While conducting some experiments in wireless telephony I made the discovery of quite an interesting combination which, to my knowledge of the art, has not been tried up to this date.

To produce mechanical effects directly, man is obliged to exert his muscular forces, by bringing his muscles in contact with the object to be moved, or through an indirect way, namely, by interposing a tool between the muscle and the object. This tool might be a lever or it might be a telegraph key, which latter, if desired, will move or disturb the far-off object through another medium, electricity.

To apply power to an object the hand is used more than any other part of the human body; the foot probably ranges

the vibrations should close a certain circuit, which in turn could be relayed, to transmit or start power, has always proved a failure on account of the vibrations of the diaphragm, created by the human voice, being exceedingly weak.

My arrangement, as described below, to transmit or start power, etc., simply by talking into a transmitter, will therefore be found novel, especially if it is considered that the transmitter is not connected with the receiving station whatsoever. The transmission is made by means of wireless electric radiations.

No new apparatus being needed in my arrangement, any amateur can easily perform the experiment.

Referring to plan, M represents the common transmitter as used on most tel-

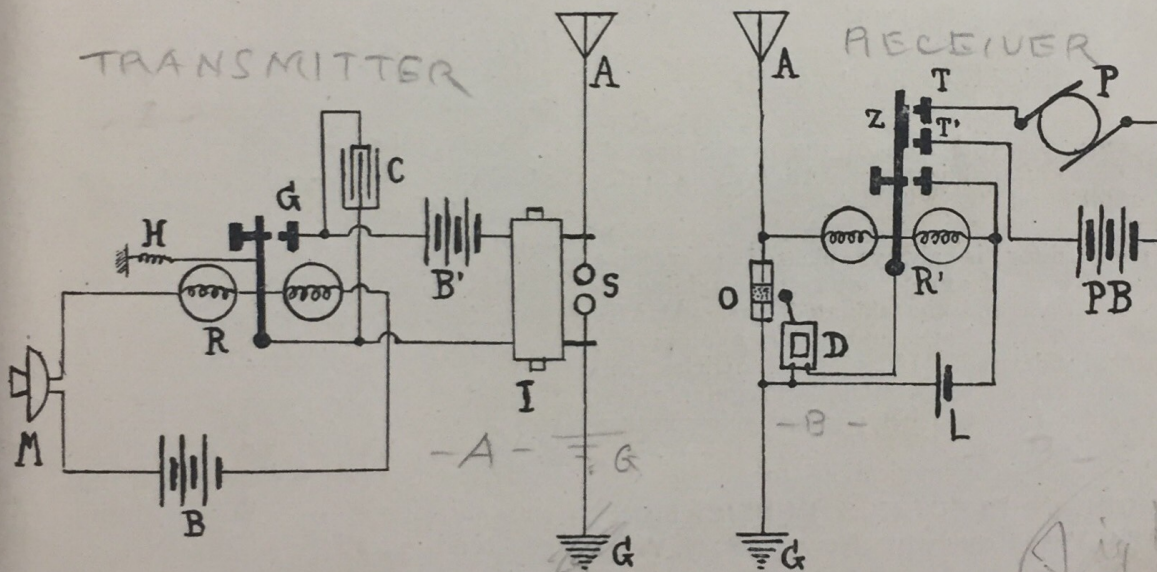

next. The whole body, mostly applied as a lever, follows. The head is practically never used at all. The lungs are used very little comparatively, for instance in glass blowing, etc.

The voice has never been used, no case being on record that a motor or a dynamo was started solely by talking, to or through a medium. I am, of course, well aware that by talking in a transmitter the telephone diaphragm at the other end will vibrate, but that can hardly be called power, it being proved that in most cases the vibrations of a receiver diaphragm measure less than one-five-thousandths of an inch. To provide a contact on the diaphragm in order that

ephones. R is a fairly sensitive pony relay of seventy-five ohms. C is a condenser to absorb excessive sparking; I, induction coil; S, oscillator balls.

The tension of the adjusting spring H on the relay should be just sufficient to keep the armature away from contact G. With a little experimenting the right tension will be ascertained.

By talking medium loud in the transmitter, the resistance in same will be varied accordingly and the armature will close the circuit at G, through battery B' and coil I, which may be a common one-inch spark-coil not deprived of its vibrator.

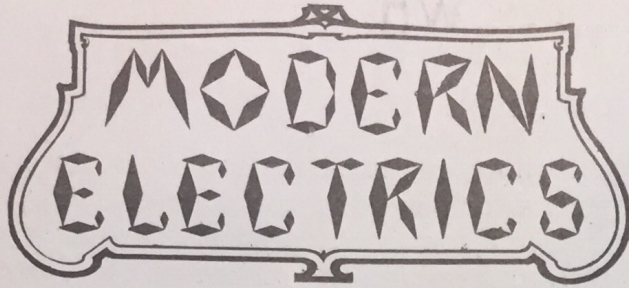

A Magazine devoted entirely to the
Electrical Arts.

PUBLISHED MONTHLY BY

Modern Electrics Publication
NEW YORK CITY, N. Y.

H. GERNSBACK, EDITOR.

**Subscription Price: For U. S. and Mexico,
\$1.00 per year, payable in advance.**

New York City and Canada, \$1.25.

Foreign Countries, \$1.50 in Gold

Stamps in payment for subscriptions *not ac-
cepted.*

Checks on out of town Banks cannot be ac-
cepted unless the usual exchange is added.

SINGLE COPY, 10 CENTS.

Forms close the 20th of the month preced-
ing date of publication. Advertising rates
on application.

The Editor is always pleased to receive
contributions of timely interest pertaining to
the electrical and the affiliated arts. Articles
with good drawings and clear photographs
especially desired. If accepted, articles will
be paid for on publication, at regular rates.
No manuscripts will be returned unless return
postage is enclosed.

Address all communications to:

**MODERN ELECTRICS PUBLICATION
84 West Broadway, New York, N. Y.**

Copyright, 1908, by MODERN ELECTRICS
PUBLICATION.

Entered as Second Class matter March 31,
1908, at the New York Post Office, under the
Act of Congress of March 3, 1879.

Vol. I. MAY, 1908. No. 2.

"MODERN ELECTRICS" has had
such an unparalleled success since its
first appearance that it became **necessary**
to give up the old offices and move to
larger quarters. We are now located at
84 West Broadway, in the very heart
of New York's electrical district, and
our present facilities are adequate to
keep pace with the rapid growth of the
magazine.

We are proud to say that out of about
600 letters received, there was *not one*
that did not contain congratulations,
a few nice words.

We were a little "shaky" at first,
we did not know if we had struck
right, but the avalanche of kind letters
received encouraged us enormously, and
we know now that we do not have
fear for the future.

We know that "MODERN ELE-
TRICS" has come to stay, for the sim-
ple reason that it fills a long-felt want
and because "we have the goods!"

A strange disease is spreading rapidly
over this country and threatens to in-
fect every young man over 15 years old.
No antidote has been discovered so far
against its ravages, and parents are
greatly alarmed, the new disease at the
same time taxing pocketbooks and check-
books heavily.

The name of the infecting germ is
Bugum Y-erlessum and creates the so-
called "Wireless Craze." The disease is
incurable.

Never before was the "craze" so
strongly developed as this year; un-
countable cases are reported from Port-
land, Me., to Portland, Ore., and the
statistics show that out of five young
men two are infected.

Since "MODERN ELECTRICS"
made its appearance a month ago, the
Editor has been flooded with mail. From
the hundreds of congratulating letters
received 159 (one hundred and fifty-
nine) up to this writing deal with nothing
but Wireless. Most readers wish to see
the "Wireless Department" enlarged,
some even went as far and asked us to
publish nothing but Wireless, a great
many wanted a description of an electro-
lytical Detector, while an equally large
audience wanted to build a Silicon De-
tector.

We had in mind to print a good many
interesting articles besides the ones in
the "Wireless Department," but our
motto is: "To print what our readers
WANT, not merely what strikes the
Editor's fancy."

We remembered this in time and the
present issue of "MODERN ELE-
TRICS" proves that our motto is no idle
boast.

A Long-Distance Writer

BY OUR BERLIN CORRESPONDENT.

The writer has had the good fortune to-day to witness some interesting tests made with Mr. Gustav Grzanna's new "Fernschreiber" (long-distance writer.)

The inventor, a young German from Berlin-Steglitz, exhibited his apparatus at the "Zoo-Hall" in Berlin. The new "Fernschreiber" has also been tested lately by the German postal authorities, and extraordinary results were obtained by transmitting handwriting, sketches, etc., by wire from Berlin to Dresden, a distance of 150 miles.

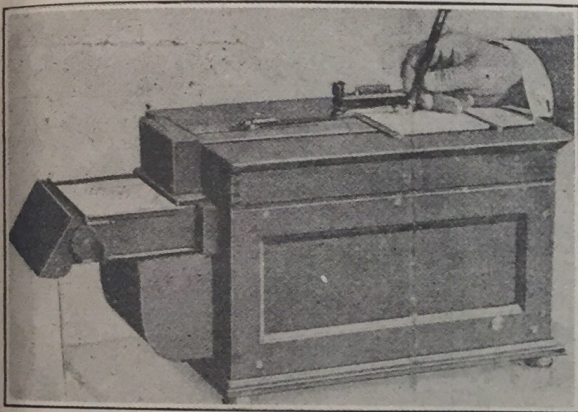

The characteristic jerks and angles which are experienced with other similar apparatus are completely eliminated. The writing is reproduced in every instance with astonishing accuracy, even on lines 500 miles long. Distance hardly affects the instruments at all.

Mr. Grzanna has solved the problem to reproduce accurately in an extremely clever manner; his method is described in the following lines:

The engraving shows the instrument in which the sender and receiver are combined all in one. Two such apparatus are connected with two wires among each other. Three wires are really necessary, but for the third one the ground is used.

A lead pencil is fastened to a lever in such a way that it will move lightly over the writing pad. It can move to the right, to the left, up or down.

This lever is arranged so that it slides over two resistance spools. During the writing, therefore, the respective movements are transmitted through a regular

telegraph or telephone line and the resulting current variations are recorded in the receiver.

The problem was to transform these variations into writing, and it is here where Mr. Grzanna has shown his genius.

One end of the line is connected to a sensitive electro-magnet. If little current is sent out from the sender, the receiving electro-magnet is magnetized little; if much current is cut in, the electro-magnet is energized more, etc.

A little mirror fastened on an iron foil is hung up in front of the pole of the electro-magnet; this mirror moves around its horizontal axis and will move more or less, according to how much or how little current is sent out from the sender.

A beam of light from a small 4-volt tantalum lamp, concentrated through a lens, is directed upon the mirror and is reflected in such a manner that it traces a vertical line, long or short, all depending how much the electro-magnet is energized. A vertical move at the sender consequently reproduces a vertical move at the receiver.

*Der Fernschreiber
ergänzt das Telefon.*

Original Message.

*Der Fernschreiber
ergänzt das Telefon,*

As the Instrument Reproduces it.

In the circuit, which is controlled by the horizontal movements of the sender, another small electro-magnet is connected at the receiver, exactly like the other one just described. Only this one has its mirror arranged in such a way that it can only trace horizontal lines, as soon as the electro-magnet is magnetized.

The two light beams are reflected in such a manner that they fall upon the same point; as soon as the magnets are in operation the light rays trace lines and curves upon a band of sensitized photographic paper. These curves and lines are nothing else than the components of the original writing and each and every move at the sending station must be accurately reproduced at the distant receiver.

The sensitized paper after passing through the fixing tanks, 10 seconds after the original dispatch was written

down, emerges from the machine, and while moist one can read the writing as well as if it had been jotted down by pen.

The instrument works automatically; all one has to do is the writing and the receiving of a message. When the apparatus is connected with the regular telephone line, quite a good deal of business can be transacted by this method, which would be quite impossible in any other way. Large business houses will undoubtedly soon adopt these wonderful "Fernschreibers."

Demonstration of Electrical Lines of Force

While it is comparatively easy to demonstrate a magnetical field with iron filings by strewing them on a piece of paper and place the magnet or magnets directly below the sheet, successful lines of force made by the electrical current itself have never been obtained heretofore.

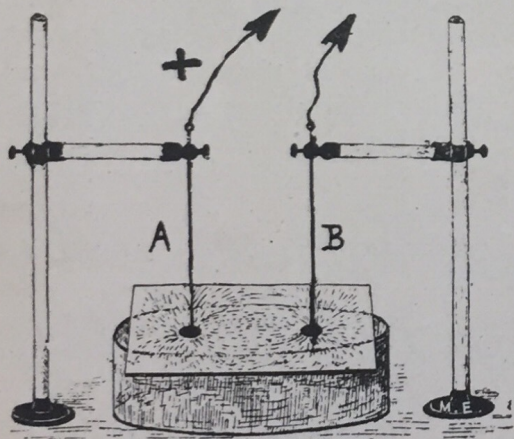

To Mr. C. Fischer belongs the honor of discovering a method to accomplish this, and as will be seen, the arrangement is simplicity itself.

To demonstrate an electrical field of either + and - poles or + and + poles, etc., paste two strictly round circles of tinfoil about 1-1½" in diameter on a clean pane of glass (see illustration). The distance these tinfoil disks should be apart must be ascertained by experiment.

The glass plate itself is placed on an insulator such as a glass vessel, hard rubber, and even four small bottles will do. Two thin metal rods A and B are

then placed in the centre of the disks, the + and - wire are connected to the discharge balls of a small static machine.

Before the machine is started the plate must be covered with a film of small light particles which should be long and thin, not round.

After innumerable trials Mr. Fischer found that crystals of gypsum gave the best results, besides having the advantage of being cheap. It is to be recommended to prepare different grades of powder; a few experiments will be the best guide.

If the machine is started the crystals will arrange themselves in certain definite lines which demonstrate the electrical lines of force.

Not too high a tension should be used in connection with these experiments, as it will tend to scatter the crystals from their true lines; irregular figures or none at all will be the result.

If the machine is too powerful one may keep the rods A and B a little distance away from the tinfoil disks, which will reduce the strength of the current somewhat.

It only takes a second or two to obtain characteristic figures. It may happen sometimes, that the lines do not form quite symmetrically; in that case simply tap the glass plate lightly with a wooden stick while the machine is in operation.

If you need a "shake-up," walk on the third rail.—"Fips."

Wireless Telephony

By NEWELL A. THOMPSON, JR.

At the present time there are three well-known methods of transmitting speech wirelessly. They are (1) by a beam of light, or as it is more commonly known, radiophony; (2) by electro-magnetic induction; and (3) by electro-magnetic waves. Each one has been fully tested, and it is safe to predict from the results and data obtained that transatlantic wireless telephony will follow closely upon the heels of its sister, wireless telegraphy.

The theory of the first method is by no means new, it being identical with Professor Bell's photophone which was invented in 1878. Since the invention of the selenium cell and speaking arc, the range of this system has been greatly increased by Ernst Ruhmer, it being only limited by the curvature of the earth and

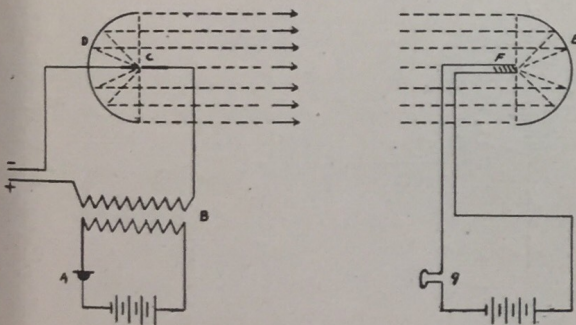

Fig. 1

a smoky atmosphere. Ruhmer's apparatus is shown in Fig. 1. In speaking into the transmitter, the oscillating current of the microphone A, is superposed by means of transformer B, on the current supplying the arc lamp C, thereby causing the amount of light radiated to vary. The parabolic mirror D, sends out these rays parallel and throws them on the concave mirror E, of the receiver. There, being concentrated on a selenium cell F, they cause the battery current to vary so that articulate speech is reproduced in the telephone receiver G. Ruhmer has carried on many experiments by this method, those in 1902 between Berlin and Falkenberg and of Wannsee Lake, Germany, where he communicated up to a distance of four kilometers, being especially worthy of note.

Let us now turn our attention to the

electro-magnetic induction method. A very good example of this means of the transmission of speech is cross talk in a telephone system; words spoken on one wire being heard in the telephone on a second parallel wire. At the St. Louis Exposition Mr. M. R. Hutchison gave an excellent demonstration of this system. Fig. 2 shows his apparatus, which

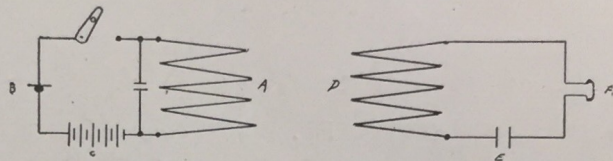

Fig. 2

is simplicity in itself. The transmitting circuit consisted of a large wire cable, A, in series with a microphone, B, and battery, C. The portable receiver was a coil, D, of wire 30 cm. in diameter, in several layers, in series with a small condenser, E, and a telephone receiver, F. On speaking into the transmitter, B, an undulatory current rotates through coil, A, thus setting up a magnetic flux, the lines of which link with the coil, D, and by its inductive action produces a momentary current in the telephone circuit. The radius of this apparatus, however, is limited by the range of the lines of force emitted from the transmitting coil, which is practically one-half of its diameter outside. Of all the three methods

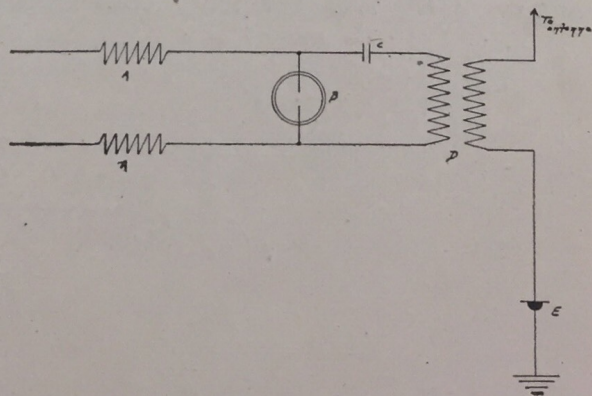

Fig. 3

this one is by far the simplest for the amateur experimenter, its success being positive within its limits.

Soon after Marconi bridged the Atlantic wirelessly, attempts were made everywhere to transmit speech by the same

methods, but these amounted to little, owing to the low frequency current used in transmitting. Electro-magnetic wave telephony has only of late become a possibility by the invention of various de-

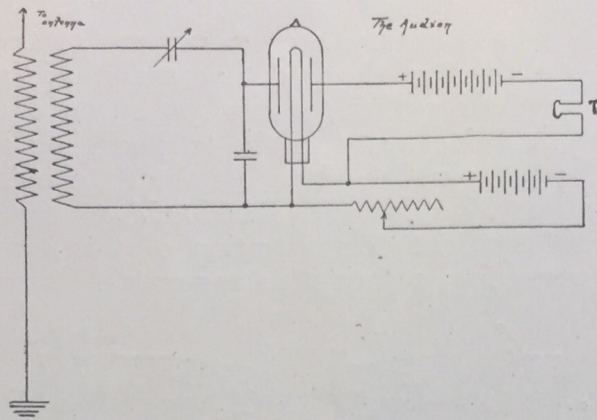

Fig. 4

vices to increase the frequency of the transmitter enough to carry the vibrations of the human voice.

Among the experimenters in this line are Dr. Lee de Forest and Professor Reginald A. Fessenden. The system of the former is now well known, since the United States Government has equipped nearly all its vessels with it, which are now encircling the globe. The de Forest transmitting apparatus is shown in Fig. 3. A current of 220 volts is led through choke coils, A, these preventing high frequency alternating currents from passing; then to the oscillator, B, which is an arc maintained in the flame of an alcohol lamp. From the oscillator the high frequency current passes through the condenser, C, and primary, D, of the air core transformer. One side of the secondary of the transformer is connected

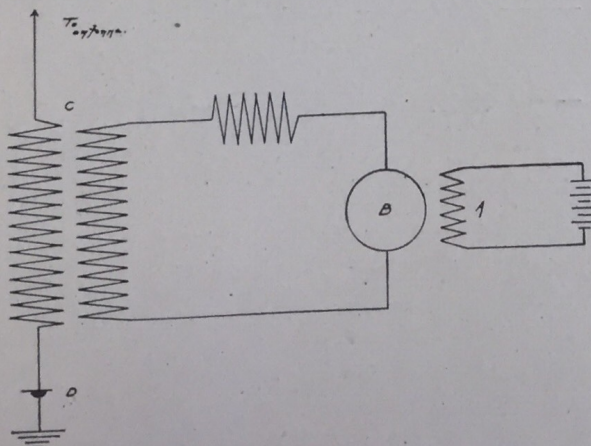

Fig. 5

to the antenna; the other to ground through a microphone, E, which varies the amplitude of the emitted waves according to the voice vibrations.

Fig. 4 shows the receiving device of this system. The keynote to its success lies in the "audion," an invention of Dr. de Forest. This apparatus is three times as sensitive than any receiving device known. The "audion" is simply an electric light with two platinum wings sealed inside. The oscillations impinge on the antenna and affect the audion through the transformer circuit. The changing amplitude of the oscillations varies the resistance of the gas ionized by the heat of the filament in the lamp, and thus causes the diaphragm of the telephone receiver, T, to vibrate, reproducing articulate speech. This system has met with instant success from its debut on Lake Erie last summer, where it was used to report the regatta of the Interlake Association. The messages were transmitted with great accuracy and no difficulties were met with.

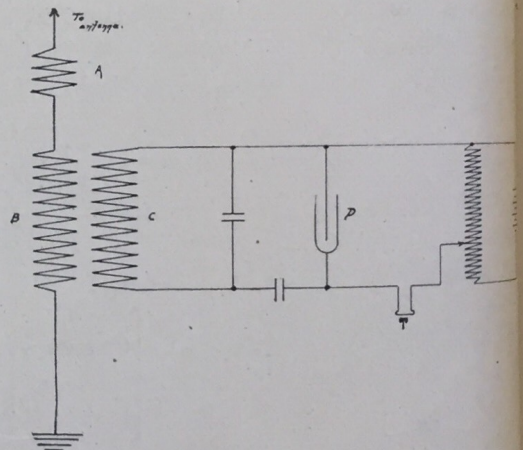

Fig. 6

The United States Government has recently placed an order with Dr. de Forest for a large number of sets of the apparatus, which is a sure sign that wireless telephony has come to stay.

Professor Reginald A. Fessenden, his immense station at Brant Point, Mass., has developed a system of wireless telephony that has given exceedingly promising results. Its theory is practically the same as Dr. de Forest's system, but his apparatus is entirely different and far more simple. Figs. 5 and 6 illustrate his methods. In the transmitter, Fig. 5, A is the excitation winding of alternator, B. This alternator is one of the most wonderful pieces of electrical apparatus ever constructed. It proves false the often made statement that a high frequency alternator of considerable output is an impossibility. This alternator is a small machine of

Morley type, with a thin fixed armature and revolving field magnet with three hundred and sixty polar projections. An alternating current of 150,000 cycles per second and an E. M. F. of 65 volts is obtained at the speed of 139 revolutions per second. Even at this high speed no trouble is experienced with the machine. From the alternator the high frequency current is led through the transformer, C, which makes the emitted wave sharp and persistent. The microphone, D, is located in the antenna at a potential node where the voltage is only about 15. The resistance change in the microphone, D, varies the current and in proportion to this variation the potential of the antenna rises and falls; therefore, the radiated waves vary in amplitude in proportion to the changes in the resistance in the microphone, D.

Professor Fessenden's receiver is identical with the electrolytic detector used in wireless telegraphy (see Fig. 6), the antenna being grounded through a tuning inductance, A, and primary, B, of a transformer, the secondary, C, is in circuit with the electrolytic cell, P.

With this apparatus working at its full capacity, ranges of over 100 miles are available. During the summer of 1906 communication was daily carried on between the Brank Rock station and a small schooner up to distances ten miles off shore. During the winter following further experiments were carried on between Brant Rock and Plymouth. Last year a station was erected in New York City, and communication is now easily carried on between that point and Brant Rock, a distance of over two hundred miles. Owing to its extreme simplicity in operation, this system is very promising. The operator has no spark-gaps or flaming-arcs to constantly adjust or renew, thus making transmission absolutely quiet, quite a contrast to the so-called "thunder factories" of Marconi.

Summing up briefly the success, little or much as it may be, obtained by these three methods, it seems that wireless telephony has come to us to stay and will eventually be developed so as to send and receive messages by the human voice at great distances and with greater speed instead of by signals as at present.

A trolley wire is no stronger than its weakest fuse.—"Fips."

A NEW SPARK GAP FOR WIRELESS.

A new method to obtain more regularity of discharges in connection with condenser circuits has been invented by a German electrician, Mr. W. Eickhoff.

It is well known that the starting of the discharge in the spark gap is somewhat irregular if condensers are used; in other words, the discharge does not always take place just when it ought to.

Mr. Eickhoff uses a brass rod and files a fine point at the free end. The other end is soldered or connected by other means to the *negative* terminal of the spark coil, as shown in sketch.

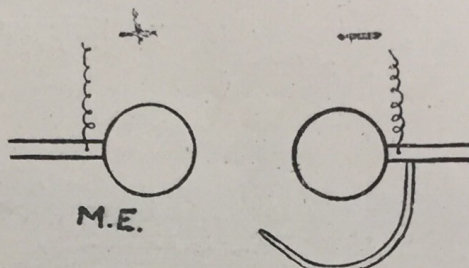

If the distance is well selected, the intensity and general appearance of the spark is not changed; the regularity of the discharge, however, is increased over 100%.

INCREASING THE EFFICIENCY OF SPARK COILS.

An interesting discovery has been made by an Englishman, Mr. A. Henry. He found that when he connected two Wehnelt interrupters in series his 1½" spark coil would give sparks up to 5¼", which at this length were even more intense than the original 1½" spark.

By means of rotating mirrors it was found that the frequency of the interruptions were 300 with one Wehnelt interrupter; by using two of same, the frequency ran up to 600. If the two interrupters are exactly alike, one observes in the rotating mirror that the platinum points get red hot alternately.

It is quite interesting, too, that by using two such interrupters in series the efficiency of a coil is greatly increased.

It was found that while with one interrupter and 90 volts across the primary and 8.5 amperes, the sparks obtained were 1½" long, but by using two interrupters with the same voltage, 5¼" sparks were obtained, and only 5 amperes were required.

No results were obtained by using two Wehnelt interrupters in parallel.

An Electric Sun Alarm

By H. GERNSBACK.

To those wishing to rise with the sun each morning the apparatus described in this article is to be recommended.

The present paper also tells how to make a SELENIUM CELL, as quite a few readers requested the description of such. A good many readers not being familiar with selenium, a few words about its characteristics and peculiarities will no doubt be welcomed.

Selenium is an element and was discovered by the famous chemist, Berzelius, in 1817. It takes its name from selen—the moon. In its crystalline form the element is a metal.

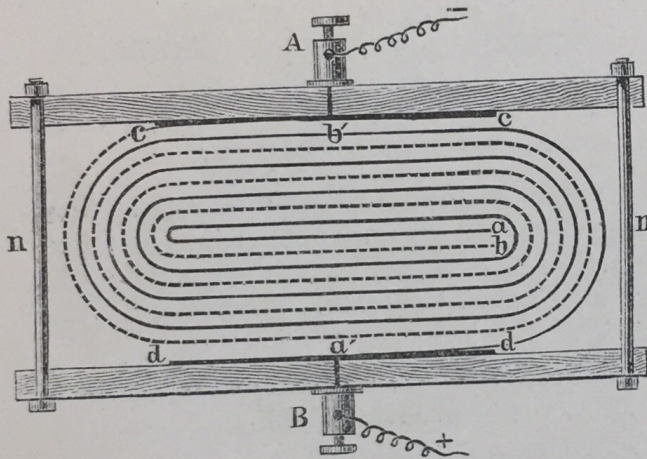

Fig. 1.

In 1873 Willoughby Smith accidentally discovered the peculiar property that selenium changed its resistance by merely exposing the metal to a source of light.

While experimenting with selenium sticks, which he used as resistances on a telegraph circuit, he was troubled a good deal by fluctuations of the current, for which he could not account. On careful investigation he found that when the cover of the box in which he had placed the selenium was closed, the current was a good deal weaker than if the box was open. Further researches established the fact that the electrical resistance of selenium varied with the amount of the light which falls upon it.

Commercial selenium usually comes in the form of sticks. If it is heated sufficiently it develops strong, poisonous, dark-red fumes, which smell quite like horseradish.

After being melted and cooled off quickly, selenium assumes a vitreous, par-

tially translucent form, and when held to the light it will be found to have a dark red color. In this state the element is non-metallic and a di-electric. In fact, it has a good many properties of its cheaper brother—glass, whom it resembles a good deal while in its vitreous state. If, on the other hand, we melt selenium and let it cool off very slowly, it will be found after cooling to have changed into a crystalline form of a slate gray color. In this state it is a metal and conducts electricity as such. It is now also opaque to light.

The construction of a selenium cell is by no means an easy task, as the metal only works successfully when applied to another metal in form of an extremely thin film.

It is quite hard, too, to establish a good contact between a selenium film and other metals and a good deal of patience is required.

A good selenium cell, however, is worth while spending time upon, as the most interesting experiments can be performed with it and new researches be carried out.

As selenium has a very high resistance, even in its crystalline form, it is necessary to offer the current numerous paths in the construction of a successful cell.

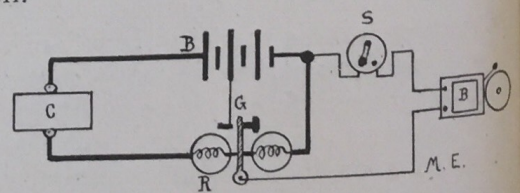

Fig. 2

A very good type of cell easy to make is shown in Fig. 1; a and b represent two brass strips, each about 2 feet long $1/16$ " thick and $1/2$ " wide. In the illustration b, is shown in a broken line to facilitate the study.

Next, the brass strips must be well polished on the edges and no rough places must occur. The strips should then be tinned evenly—an operation which any plumber can perform for you. This tinning is necessary, as it has been found that selenium adheres better to a tinned surface than to brass.

We now cut a strip of heavy parchment paper 24" long and $1/2$ " wide. This

we place between the two prepared brass strips, a and b (not shown in illustration), and proceed to wind the strips into an oval spiral. It is of the utmost importance that this winding is done accurately, as the finished spiral must be absolutely smooth and straight on the face where the selenium is to be applied. A steel square can be used to good advantage; it will greatly facilitate to obtain a smooth and even surface.

Two oak boards which have a connecting plate, c c and d d respectively, and which are in metallic connection with two binding posts, A and B, are now constructed and the completed spiral is clamped between these boards by means of the two bolts, n n, as shown in illustration. The brass strips, a' and b', connect with the plates, c c and d d, respectively.

The idea of the parchment strip is to separate and insulate the metal strips from each other effectively, and if a telephone receiver, in series with battery is now connected to binding posts, A and B, not the slightest sound should be heard. This shows that the insulation is perfect.

After the face of the block is well polished and absolutely smooth and straight, it is ready to receive the film of selenium, which is best done in the following manner:

The whole arrangement is placed in an iron vessel, the bottom of which is covered with clean, dry sand. We now pour sand all around the cell so that only the polished surface remains uncovered. We then place the vessel over a Bunsen burner or on a hot stove and let the cell heat till a selenium stick, when tried, will melt freely. As soon as this temperature is reached the vessel should be taken from the heat and the selenium stick should be rubbed over the entire surface of the prepared face of the block. It is of the utmost importance that as thin a film as possible is obtained, as the completed cell will not be sensitive at all if too much selenium is applied.

As soon as the selenium is well distributed, the vessel with the completed cell must be placed in a tin or other metal box and the cell baked in an oven for about half an hour. Attention is called to the fact that it is necessary to maintain the temperature at 250 degrees Fahrenheit during this time. After that

the temperature should be reduced as quickly as possible. Slow cooling will give bad cells.

The selenium cell is now ready for use, and to prevent its surface from being scratched or damaged it should be painted with a thin layer of a very clear solution of shellac in alcohol.

If the cell is well constructed it will have a resistance of about 600 to 700 ohms in the dark. In full sunlight this resistance may fall below 300 ohms.

The writer constructed cells as per above description, which would ring a bell through a relay if a match was lighted near it in the dark.

The selenium cell can be put to a variety of uses; the best known one probably is found in Prof. Graham Bell's radiophone, in which transmission of speech is effected by means of light rays without wire connections. This was the first wireless telephone.

A beam of light is thrown upon an extremely thin reflecting mirror in such a way that the reflected rays from the mirror fall upon a distant selenium cell. If one speaks now on the back of the mirror, same is made to vibrate, and the beam of light changes in intensity accordingly. A telephone receiver in series with the distant selenium cell records all these changes and in this manner the voice is reproduced clearly.

Selenium cells have also been found useful in connection with telescriptors, that is, instruments which transmit writing, drawings, photographs, etc., by wire.

The electric sun alarm is easy to construct and the connections are effected, as shown in diagram — Fig 2.

C is the selenium cell which is connected in series with about 8 or 10 dry cells and a 75-Ohm or, better, 150-Ohm standard relay, R, which must be adjusted as fine as possible. A mere breathing against its armature must close the contacts, G. The local circuit (light lines) consists of two dry cells in series with switch S' and alarm bell, B.

The selenium cell is placed in a box which has a glass cover, to prevent the cell from being damaged. The completed cell when wired up (use flexible cord) is placed on the window sill and inclined in such a manner that the face which has the selenium film is directed skywardly.

Wireless Department

Wireless Telegraph Oddities

BY SIGNOR GUGLIELMO MARCONI.

"On Nov. 27, 1901, I left for Newfoundland with two assistants. As it was impossible at that time of the year to set up a permanent installation with poles, I decided to carry out the experiments by means of receivers connected to elevated wires supported by balloons or kites—a system which I had previously used when conducting tests across the Bristol Channel for the British Post Office in 1897.

"It will be understood, however, that when it came to flying a kite on the coast of Newfoundland in December, this method was neither an easy nor a comfortable one. When the kites were got up, much difficulty was caused by the variations of the wind producing constant changes in the angle and altitude of the wire, thereby causing corresponding variations in its electrical capacity and period of electrical resonance.

"My assistants at Poldhu, in Cornwall, England, had received instructions to send on and after December 11, during certain hours every day, a succession of 'S's' followed by a short message, the whole to be transmitted at a certain prearranged speed every ten minutes, alternating with five minutes' rest.

"On December 12 the signals transmitted from Cornwall were clearly received at the prearranged times, in many cases a succession of 'S's' being heard distinctly, although, probably in consequence of the weakness of the signals and the constant variations in the height of the receiving aerial, no actual message could be deciphered.

"The following day we were able to confirm the result. The signals were actually read by myself and by my assistant, Mr. G. S. Kemp.

"The result obtained, although achieved with imperfect apparatus, was sufficient to convince me and my co-workers that by means of permanent stations—that is, stations not dependent on kites or balloons for sustaining the elevated conductor—and by the employment of more power in the transmitters

it would be possible to send messages across the Atlantic Ocean with the same facility with which they were being sent over much shorter distances.

"About two months later, in February, 1902, further tests were carried out between Poldhu and a receiving station on board the American liner Philadelphia en route from Southampton to New York. The sending apparatus at Poldhu was the same as that used for the Newfoundland experiments. The receiving aerial on the ship was fixed to the mainmast, the top of which was 60 meters (197 feet) above sea level.

"As the elevated conductor was fixed and not floating about with a kite, as in the case of the Newfoundland experiments, good results were obtained on a syntonic receiver, and the signals were all recorded on tape by the ordinary Morse recorder.

"On the Philadelphia readable messages were received from Poldhu up to a distance of 1,551 miles, 'S's' and other test letters as far as 2,099 miles.

"The tape records of the signals are in my possession, and some of them are here exhibited to-night. The distances at which they were received are all verified and countersigned by the Captain and chief officer of the ship, who were present during the tests.

"A result of some scientific interest, which I first noticed during the tests on the Steamship Philadelphia, was the very marked effect of sunlight on the propagation of electric waves over great distances.

"At the time of these tests I was of the opinion that this effect might have been due to the loss of energy at the transmitter by daytime, caused by the dielectrification of the highly charged transmitting elevated conductor operated by the influence of sunlight. I am now inclined to believe that the absorption of electric waves during daytime is due to the ionization of the gaseous molecules of the air affected by ultra-violet light, and as the ultra-violet rays which emanate

nate from the sun are largely absorbed in the upper atmosphere of the earth, it is probable that the portion of the earth's atmosphere which is facing the sun will contain more ions or electrons than that portion which is in darkness, and therefore, as Prof. J. J. Thomson has shown, this illuminated and ionized air will absorb some of the energy of the electric waves.

"The fact remains that clear sunlight and blue skies, though transparent to light, act as a kind of fog to powerful Hertzian waves. Hence the weather conditions prevailing in this country are usually suitable for long-distance wireless telegraphy.

"The operation of the long-distance stations in England and America made it possible to transmit messages to ships, whatever their position, between Europe and North America, and to the Cunard Company belong the credit of having greatly encouraged the long-distance tests, a circumstance which enabled them to commence, in June, 1904, the regular publication on their principal vessels of a daily newspaper, containing telegraphic messages of the latest news from Europe and America.

"This daily newspaper has now been adopted by nearly all the large liners plying to New York and the Mediterranean, and it obviously owes its entire existence to long-distance wireless telegraphy.

"In some of my earliest experiments in 1896 I used copper mirrors, by the aid of which it was possible to project a beam of electric radiation in a certain direction, but I soon found that this method would only work over short distances.

"About three years ago I again took up the subject, and was able to determine that by means of horizontal aerials, disposed in a particular manner, it was possible to confine the effects of electric waves mainly to certain directions as desired. True, the limitation of transmission to one direction is not very sharply defined, but it is nevertheless very useful.

"The practical result of this method has been so far that messages can be sent over considerable distances in the desired directions, while they travel over only a comparatively short distance in other directions, and that, with aerials of moderate height, greater efficiency in

a given direction can be obtained than can be obtained all round by means of the ordinary aerials.

"When this type of aerial was adopted at Glace Bay, a considerable strengthening of the received signals at Poldhu was noticed. It was, therefore, decided to adopt the directional aerial at all long-distance stations.

"A further improvement introduced at Clifden and Glace Bay consisted in the adoption of air condensers, composed of insulated metallic plates suspended in air at ordinary pressure. In this manner it is possible to prevent the dissipation of energy due to losses caused by the dielectric of the condensers previously employed, and a very appreciable economy in working, resulting from the absence of breakages of the dielectric, is effected. These air condensers, which have been in use since May of last year, have been entirely satisfactory.

"After considerable time and expense the new station at Clifden was got ready for tests by the end of May, 1907, and experiments were then commenced with Glace Bay.

"The messages can now be transmitted across the Atlantic by day as well as by night, but there still exist certain periods, fortunately of short duration, when transmission across the Atlantic is difficult, and at times ineffective unless an amount of energy greater than that used during what I might call normal conditions is employed.

"Thus in the morning and evening, when, due to the difference in longitude, daylight or darkness extends only part of the way across the Atlantic, the received signals are weak and sometimes cease altogether.

"It would almost appear as if illuminated space possessed for electric waves a different refractive index to dark space, and that in consequence the electric waves may be refracted and reflected in passing from one medium to the other. It is, therefore, probable that these difficulties would not be experienced in telegraphing over equal distances from north or south, or vice versa, as in this case the passage from daylight to darkness would occur almost simultaneously in the whole of the medium between the two points.

"In the same manner a storm area in the path of the signals often brings about

a considerable weakening of the received waves, while if stormy conditions prevail all the way across the Atlantic no interference is noticeable. Electric wave shadows, like sound shadows, may be formed by the interference of reflected waves with the direct waves, whereby signals may be much less effective or imperceptible in the area of such electric wave shadow.

"In the same manner as there exist periods when signals across the Atlantic are unusually weak, there exist other conditions, especially at night, which make the signals abnormally strong. Thus on many occasions ships and stations equipped with apparatus of a normal range of 200 miles have been able to communicate over distances of over 1,000. This occurred recently, when a ship in the English Channel was able to correspond with another in the Mediterranean. But the important factor about wireless telegraphy is that a service established for a certain distance shall be able to maintain reliable communication over that distance.

"The erection of long-distance stations for the purpose of telegraphing across the Atlantic met at the outset with the severe criticism of a certain important section of the English technical press, which, although one would imagine it existed for the purpose of encouraging and promoting the progress of electrical science and industry, always seemed more inclined to champion the particular interests of the cable companies.

"Without wishing to enter into any controversy on this point, I venture to predict that some of the statements published with reference to long-distance wireless telegraphy will make very amusing reading in a few years to come.

"Long-distance stations are now in course of erection in many parts of the world, the most powerful of all being that of the Italian Government at Coltano, and I have not the slightest doubt that telegraphy through space will soon be in a position of affording communication between distant countries at cheaper rates than can be obtained by any other means.

"As to the practicability of wireless telegraphy working over long distances such as that separating England from

America, there is no longer need for any doubt. Although the stations have been worked for only a few hours daily, 119,945 words of press and commercial messages had been transmitted across the ocean by this means up to the end of February last, since the service was opened.

"The best judges of a service are those who have made use of it, and among newspapers the chief users have been the *New York Times* and the *London Times*, which have already publicly expressed their opinion of this new method of communication.

"Whether the new telegraphy will or will not injure or displace the cables is still a matter of conjecture, but in my opinion it rests a good deal on what the cables can do in the way of cheaper rates.

"Whatever may be the view as to its shortcomings and defects, there can be no doubt that wireless telegraphy across the Atlantic has come to stay, and will not only stay but continue to advance.

"Cable telegraphy across the Atlantic was subjected at the commencement to a series of discouraging failures and disappointments, but whatever its difficulties I think I am not unjust in saying that it enjoyed one advantage over wireless telegraphy, namely, that it was free from the natural hostility of vested interests representing over sixty millions sterling, now invested in cables, which rightly or wrongly consider long-distance telegraphy as menacing their interests.

"In seven years the useful range of wireless has increased from 200 to 2,500 miles. In view of that fact, he will be a bold prophet who will venture to affirm what may not be done in seven years more.

"Among many people there seems to be a rooted conviction that wireless telegraphy is not suitable for the handling of code or cipher messages. Whatever gave rise to this idea I do not know, but I wish to emphasize that it is purely fictitious. Code messages can be sent just as well by wireless as by ordinary methods of telegraphy.

"I do not wish to claim that wireless telegraphy is infallible, and although errors do sometimes occur it is absolutely certain that, having regard to the London and Montreal service, most of the mistakes can be traced to the land line telegraph transmission between London

The Simplest and Most Efficient Wave Detectors and How Amateurs Can Make Them

By J. STUART FREEMAN.

The possibility of transmitting electric waves without wires has been known to exist, since Hertz in 1887, performed his well-known experiment with a spark coil and an incomplete metal hoop. It was some years later, however, before Marconi gave the world the wireless telegraph, the result of long years of experimental and research work. This was

First, we will look into the construction of a mechanical coherer and de-coherer with which all the pioneer research work was accomplished.

Fig. 1.—(A) is the top view of one of these, made on the plan of the original Marconi type and (B) of the same figure is the elevation of the coherer alone. (C) is a piece of glass tubing $1\frac{1}{2}$ " in length, $\frac{1}{8}$ " inner diameter, and of sufficient strength to withstand the tapping of the metal ball, (I). Inside of this tube are fitted two pieces of brass nicked-plated rod (O' and P') preferably, and as snugly as possible. (O') is clamped fast by the binding post (D'), while (P') has a thread on it—or is soldered to the head of a dry battery binding post—and can be adjusted by the nut (N'). After the proper adjustment of this is obtained, the binding post (B') clamps it in its correct position.

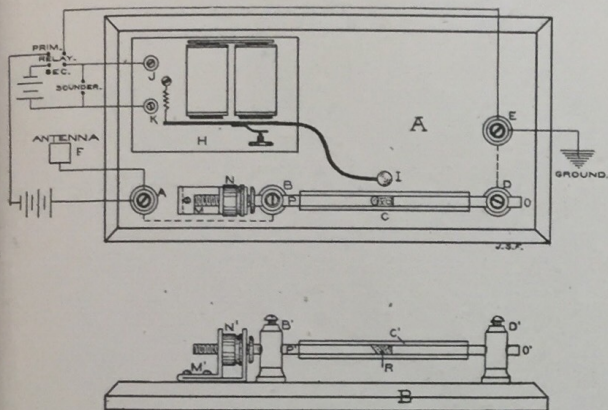

FIG. 1.

looked upon as one of the greatest mysteries of the age, while now, although just as wonderful, it is spoken of with more or less intelligence by even the layman.

But how many of the countless millions who have electric bells, medical coils, etc., in their very homes, realize that they are surrounded constantly by these unseen, silent, mysterious waves of the ether in which they live? For every time a caller presses our push button and the clapper of the bell vibrates, there are set in motion countless impulses in the surrounding medium which, were they intercepted by the right instruments, would sound as loud as the distinct buzzing in an ordinary telephone receiver. "But," you say, "there is the difficulty. Those 'instruments' cost a great deal of money." Yes, that is true in some cases, but it is surprising how many simple and inexpensive devices the experimenter has discovered, during the past few years, that will answer the purpose admirably. For instance, the writer has known of boys in their teens receiving messages in Washington, D. C., sent from Brant Rock, Mass., with no more expensive wave detectors than those he will attempt to describe below.

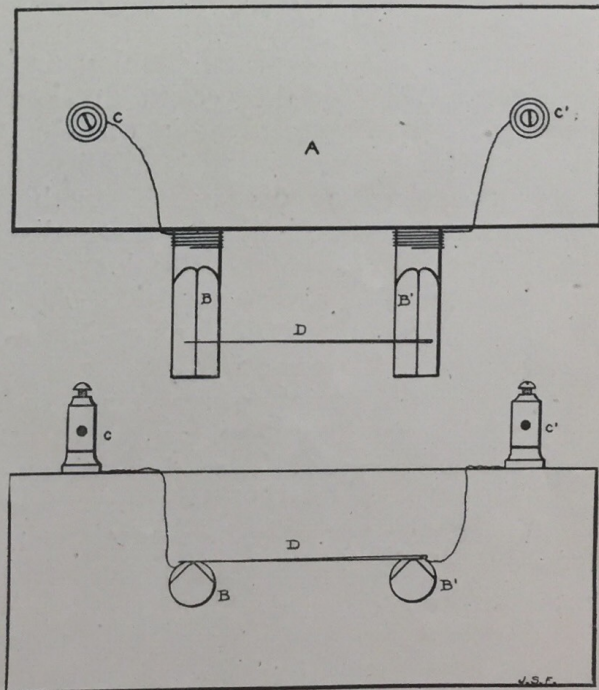

FIG. 2.

Experimenters have found that either one or both of the rods should be made to slant on the inside end, as shown in the diagram. This insures better contact of the filings with the electrodes and admits of more efficient setting. The adjusting mechanism the writer made in its simplest and most economical form:

(M') is a piece of bent sheet brass, $\frac{3}{8}$ " wide, with holes drilled in it for the screws and the rod (P')—or bolt, as suggested above—and the set screw (N') is taken from a dry battery binding post. The bell (H) is of any type employing a vibrating tapper with a ball (I) on the end. The gong is better removed to eliminate the unnecessary noise. At (R) are placed coarse nickel and silver filings in the proportion of 96% of the former

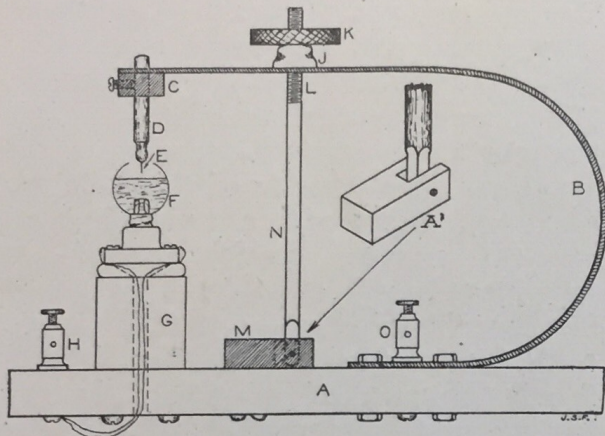

FIG. 3.

to 4% of the latter. To add to the sensitiveness of the instrument, the ends of the rods (O' and P') should be slightly amalgamated with mercury.

This coherer is one of the simplest and most serviceable for the receipt of slow messages. Its arrangement in the electric circuit is shown in the drawing.

For the reception of fast telegraphic messages, and especially for long distances over which the oscillations are very weak, auto-coherers should be used. In these decoherence takes place immediately upon the cessation of the impulses. Of the various forms tried, the electrolytic ones have been proven to be the most serviceable. But, before taking up the latter, we will describe a few of the former that have been given considerable entertainment to amateurs and experimenters.

In general the same instrument is used as that represented by Fig. 1-B, without a decoherer. Also the inner ends of the electrodes are cut off squarely, instead of slantingly. And, in every case, the tube and its contents should be absolutely dry.

In one style a small globule of mercury, a little less in diameter than the bore of the tube, is placed in the tube with a half dozen or so fairly large pieces of graphite placed on each side to keep the metal rods from coming into

direct contact with the mercury. However, if graphite or carbon electrodes are employed, no filings are necessary. The electrodes in every case are run together until a very faint buzzing sound takes place in the telephone receiver, and, if finely adjusted, this style is especially serviceable.

Another form contains only granulated graphite between carbon plugs. Still another employs aluminum filings and electrodes of the same metal.

Of the auto-coherers other than electrolytic, there is one type in which practically no adjustment is necessary. When used in very weak, long-distance work, success cannot be assured, but in lectures and experimental work exceedingly fine results have been obtained with it.

Fig. 2 shows a top and front view of this form and it will be seen that it is simply a "microphone" coherer.

(A) is a solid block of dry, hard wood with holes drilled into the front and into which are wedged two electric light carbons (B and B'). These are filed so that a cross-section taken near the outer ends resembles an inverted "V" with the angle slightly rounded. From these wires are run to binding posts (C and C') on top. To make the instrument complete, a steel darning needle is lightly laid across the carbons so that only a very slight sound is audible in the telephone receiver.

Of the various kinds of auto-coherers and methods of adjusting the same, the one represented by Fig. 3 has been proved to be the most reliable by the United States navy, and is now in use in most of, if not all, its land stations.

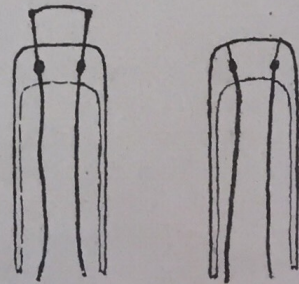

FIG. 4.

The figure is a sketch of a wave detector made by the writer on the plan of the one used in the Washington navy yard. It is very delicate, though easily and cheaply made, and, when not in use, the needle should be raised and the whole instrument shunted from the main cir-

cuit to protect it from heavy, near-by oscillations, principally those of the local station when sending.

In the diagram (A) is a firm base with slight or negligible vibration. (B) is a rather stiff piece of spring brass $\frac{1}{2}$ " in width and 15" long. One end of this is fastened securely to the base, while on the other end is soldered an oblong binding post (C) which holds the short metal rod (D), into the end of which is soldered a piece of fine platinum wire (E), sharply pointed. The platinum point dips into some form of glass vessel containing the electrolyte, supported on a base (G) of hard rubber, fibre or hard wood. The simplest form of vessel is a broken miniature incandescent lamp (F) with a small hole made in the top and all of the filament, cement and protruding lengths of the platinum "leading-in" wires removed, as in Fig. 4. This lamp can stand in its regular porcelain receptacle and from the binding screws of the same, wires are run to the binding post (H).

the use of a 20% solution of either nitric or sulphuric acid, and neither of these will attack the platinum point to any appreciable degree. In adjusting the instrument, the set screw (K) is revolved slowly until the point (E) barely touches the surface of the electrolyte, which point is recognized by a faint sound in the telephone receiver in the circuit.

In regard to the connections of the coherers described above in their electrical circuits, only the general connections will be given in this paper. These are as shown in the diagram, which explains itself.

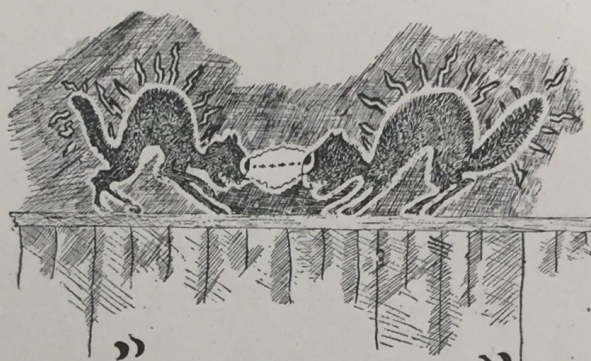

—Modern Electrics—

We are indebted to Mr. V. F. Alderson of Downs Grove, Ills., for the accompanying picture; we publish it gladly on account of its originality.

We only have one suggestion: If we had been Mr. Alderson we would have placed one of the sweet singers on a "third rail" or on a trolley wire—it would have been a bit more "modern."

As it is, we cannot quite see where the "MODERN ELECTRICS" comes in. We even have a suspicion that Adam already threw his boot or a brick out of the window when his neighbor's cats gave a free concert on the fence nearby.

P. S.—"Fips," our office boy, just came in and explained to us that electricity was not invented at Adam's time; we consequently are forced to take it all back and apologize to Mr. Alderson.

If you are easily shocked, don't come to New York, you might accidentally walk on the "BATTERY."—*"Fips."*

It is simple to invent a new trolley wheel;—a dozen are patented each week—pretty hard though to sell three of them in a year.—*"Fips."*

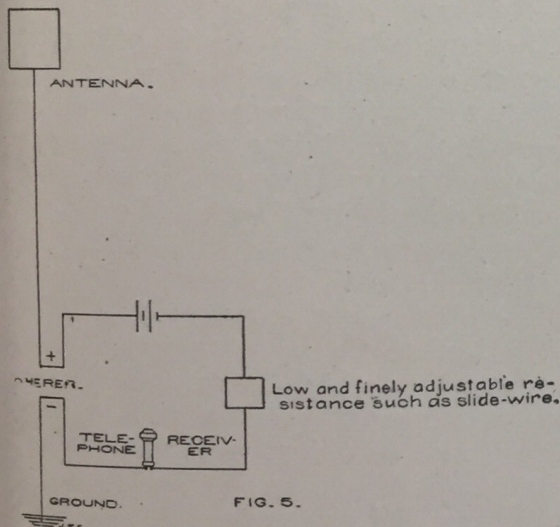

At a convenient distance between the base (G) and the binding post (O), some form of anchorage is located for the adjusting rod (N). (A' of Fig. 3 is an isometric projection of one simple form.) Directly above (M) is a hole, drilled in (B) with a hollow bushing (J) soldered over it. The brass rod (N) is $\frac{1}{8}$ " in diameter and 8" long, with a fine thread on the upper end. The brass wheel (K) is at least $1\frac{1}{2}$ " in diameter and is threaded so as to revolve easily around the rod (N) on the thread.

This completes the instrument except for the electrolyte in the vessel (F). Very good results have been obtained by

How to Remedy Troubles in Wireless Telegraph Instruments

(Concluded.)

Experimenters and amateurs usually prefer the filings coherer on account of its simplicity and because loud signals are obtained with that type. Audible signals are especially desired for demonstration purposes, and the best working detector in connection with the finest 1,000 ohm telephone receiver would naturally be of little use in demonstrating wireless telegraphy to a large audience, or to a novice, to whom the faint click in the telephone receiver would not convey the idea of space telegraphy as well as a coherer in parallel with a loud hammering sounder.

While the common filings coherer is fairly reliable, it is not possible to transmit with same messages as fast as with auto-coherers or detectors. The usual speed of the filings coherer is about 12 to 15 words per minute.

On account of this, modern wireless stations usually employ the filings coherer for calling only; the message proper is read through a detector by means of high resistance telephone receivers. As soon as the operator hears the call bell or sounder, he cuts out the filings coherer by means of a double-throw knife switch, which connects the antennae to the detector. He then takes the message, after which the aerial is again connected to the coherer and its call apparatus, ready to await the next message.

Of course this arrangement can only be used where the distance from the sending station is not too great to affect the filings coherer. If the range becomes too wide, it will be necessary for the operator to keep the receivers continuously to the ear.

In this instance we might add that the greatest distance with which the filings coherer can be operated successfully does not exceed 300 miles. While Marconi received signals on tape over 1,000 miles distant from the sending station, no really intelligible messages could be recorded.

FILINGS MIXTURES.

In a previous chapter of this paper we have called attention to the fact that the whole success of the perfect working

of a filings coherer centers in the filings. We have also pointed out how necessary it is to keep humidity and especially oil or fatty substances from coming in actual contact with the filings, but of equal importance are the filings themselves.

Many experimenters have been grieved time and again through the impossibility to obtain the right mixture, and it is quite surprising to find how many misleading articles are published every year in text-books and in periodicals on this topic. The writers in most cases probably never tried their own "receipts," or they would have been soon convinced that while, for instance, a filed up 5 cent piece, mixed with a few filings of a dime, might work satisfactory for a distance of 3 feet, things change quite a good deal when it comes to signal over 500 feet or over 1 mile.

The most common mixture used is nickel and silver in the following proportions: Nickel 96, silver 4 parts. While this mixture works fairly well for short distances, if the pure metals have been used for making the filings, it cannot be claimed that such a combination has ever been used successfully for even a short distance of 1 mile.

The misleading receipts published so often are to be traced directly to the patent claims of the inventors, who, naturally wishing to keep the right formula for themselves, simply change the proportions of the materials used and ever substitute different metals.

This is quite a common occurrence and we cannot expect that inventors will give away such receipts which not only represent a generous outlay, but also hard work of months, and maybe years on the part of the investigator.

It may be assumed that Marconi and other early workers used the nickel-silver combination, but we feel quite certain that for long distance work very different metals than the mentioned ones were used.

In fact, nickel has long been discarded for several good reasons.

For coherers it is essential that coarse and very sharp filings are used. Nickel may work very well at the start, but be

ing a very soft metal, the sparking between the filings themselves will soon wear away the sharp projections and the coherer will be found to refuse working altogether after a short while. Also nickel is entirely too oxidizable and will soon be covered with oxide, which raises the resistance of the coherer in a short time more than double the amount it was at the start.

As a rule filings mixtures are a combination of an oxidizable and an unoxidizable metal. The unoxidizable one as for instance, silver, serves to decrease the resistance of the mixture and only a very small percentage of same is used. Too much silver, or silver alone, makes a coherer useless on account of oversensitiveness.

When making filings it is absolutely necessary that a very coarse *new* file be used. If a new file cannot be obtained, an old one may possibly do after it has been soaked in strong ammonia for half an hour and then rinsed in very clean, hot water and dried over a hot stove.

No results will ever be obtained with a fine file; filings obtained in such a manner are not sharp enough and resemble more a metal powder, which of course is the worst thing that could ever be put in a coherer tube.

The metal bar of which the filings are to be made must be clamped in a vise. In a clean sheet of paper a hole of the size of the metal is then cut and slipped over the metal bar. The edges of the paper are then turned up straight all around, to keep the filings from falling down. The paper is bent downward in such a way that the operation of filing does not interfere with the sheet.

The filing itself must be practiced. Only long, slow, powerful strokes of the file will furnish good filings; quick filing gives too small particles.

The ideal size of a filing is about $3/64$ to $1/16$ " thick, the length about $1/16$ to $5/64$ " long. The corners or edges must be very sharp and well defined.

When enough filings are obtained of each metal, they should be sifted through a fine, small hair sieve to separate the small worthless filings from the valuable large ones. The good filings must now be weighed to proportion on a fine scale and then mixed, which is best done by pouring the filings in a very clean test tube and shaking the contents violently.

Of course the opening of test tube is to be closed with a piece of clean paper and not with the uncovered thumb.

The resulting mixture should now be tested in a coherer, and if found satisfactory the remaining filings should be kept in a small glass vial which had been washed out previously and dried carefully over the stove. When taking out new filings from the bottle use nothing but a clean, rather stiff piece of paper bent in V form.

The metals used for making filings must be pure; alloys, as for instance a 10 cent silver dime, are worthless for coherers, on account of the admixture of other metals used, to keep the silver piece from wearing off too rapidly.

A combination which has been in use for years, while expensive, gives excellent results. It is made by mixing 90 to 95 parts of gold with 5 to 10 parts of bismuth. This has been used successfully for long distance work and has always given satisfaction.

A combination which we have used for years and which has the advantage of being cheap and suitable as well for short as for long distance work, is made by using a certain kind of soft steel and pure silver in the following proportions: Steel 88 parts (by weight), silver 12 parts. This proportion must be strictly observed; little changes in same will make useless combinations, as only in above proportions the mixture will be successful. The steel which we have in mind is very grainy and coarse; fine-grained, or so-called "smooth," steel does not give quite as good results.

We are somewhat surprised at the lack of interest shown in our "Wireless Telegraph Station Contest." A Three Dollar prize for a photograph is considered a fair reward. What seems to be the trouble? If you cannot take a photograph yourself, have somebody else take it for you. You will always have use for it, even if we do not reprint it. If you should become a famous man during the years to come, you would most assuredly regret it not to possess a picture of your experiment room of the happy days of the past. Again we say: Get busy and come out of the dark, it is to your own interest.

Electrical Patents for the Month

884,501. MEANS FOR MEASURING THE DEGREE OF EXPOSURE OF A SELENIUM-CELL. ARTHUR KORN, Munch, Germany. Filed Aug. 1, 1906. Serial No. 328,813.

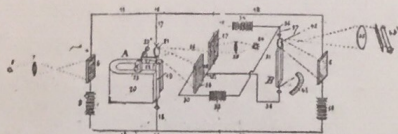

1. In a means for measuring the degree of exposure of a selenium cell, the combination with two selenium cells, of two sources of current separately connected with said two selenium cells, a line connecting said two selenium cells, a line connecting said two sources of current in series, a conductor connecting said two lines, means for exposing one of said two selenium cells to the light to be measured, and a galvanometer in said conductor and adapted to control the exposure of the other selenium cell a constant source of light in accordance with that of the first selenium cell.

884,071. SPACE TELEGRAPHY. SEWALL CABOT, Brookline, Mass., assignor to Stone Telegraph and Telephone Company, Boston, Mass., a Corporation of Maine. Filed Dec. 31, 1906. Serial No. 350,257.

1. In a system of space telegraphy, an elevated conductor system comprising a laterally extending conducting surface having its inner portion cut away and its perimeter large compared with its distance above the earth.

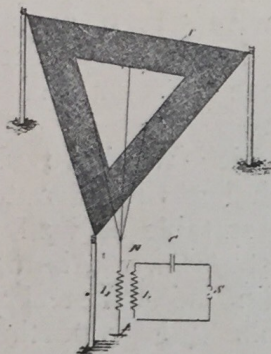

883,241. WIRELESS RECEIVING INSTRUMENT. FREDERICK G. SARGENT, Westford, Mass. Filed May 22, 1907. Serial No. 375,224.

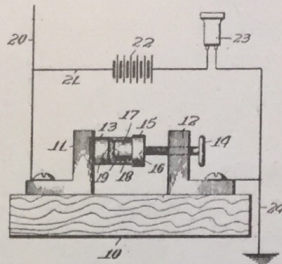

1. A coherer for a receiving instrument of the class described, comprising a loose, dry mechanical mixture of fine particles of zinc and carbon.

884,989. WIRELESS TELEGRAPHY. GUGLIELMO MARCONI, London, England, assignor to Marconi Wireless Telegraph Company of America, a Corporation of New Jersey. Original application filed Nov. 28, 1902, Serial No. 132,974. Divided and application filed Feb. 2, 1903, Serial No. 141,399. Again divided and this application filed Feb. 9, 1904. Serial No. 192,730.

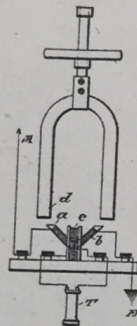

1. In a wireless telegraph system, the method of detecting electrical oscillations of high frequency, which consists in creating a rotating magnetic field at a receiving station, abruptly varying said field by the received oscillations, and utilizing the variations in said field to create intelligible signals.

883,335. ELECTRIC THEFT-ALARM SYSTEM. JOHN J. O'CONNOR, St. Paul, Minn. Filed Sept. 26, 1907. Serial No. 394,652.

1. In an alarm system of the class described, the combination, with an electric circuit and an alarm device controlled thereby, of a separable loop arranged in the circuit and adapted, when separated, to be passed through articles of merchandise.

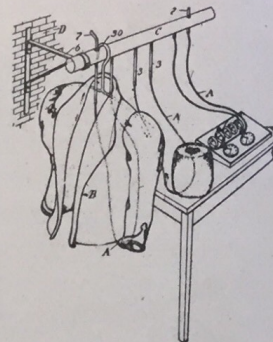

883,437. RECEIVER FOR SPACE SIGNALING SYSTEMS. LEONARD D. WILDMAN, San Francisco, Cal. Filed July 24, 1906. Serial No. 327,591.

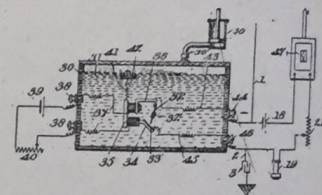

1. Receiving apparatus for space signaling by Hertzian oscillations, comprising a conductor arranged to be excited by said oscillations, relatively movable conducting surfaces in close proximity to each other, means normally separating said contacts but permitting contact when said oscillations are received on said conductor, said means-reestablishing said separation after the passage of each oscillation, and means to damp the movement of said surfaces.

Electrical Inventions for Which Letters Patent Have Been Granted for the Month Ending April 14th.

- 882,553, 882,554. BLOCK-SIGNAL SYSTEM. Fred B. Corey, Schenectady, N. Y.
- 882,555. ELECTRIC SIGN. Samuel E. Doane, Cleveland, Ohio.
- 882,563. REPEATING FIREARM. Lewis L. Hepburn, New Haven, Conn.
- 882,564. ELECTRIC HEATER. Edward M. Hewlett, Schenectady, N. Y.
- 882,569. RHEOSTAT. Charles D. Knight, Schenectady, N. Y.
- 882,570. BURGLAR-ALARM. Cosmo Liaci, New Haven, Conn.
- 882,573. STORAGE BATTERY. William L. Merrin, Fredericktown, Ohio.
- 882,581. INDUCTION-MOTOR CONTROL. Karl A. Pauly, Schenectady, N. Y.
- 882,586. ELECTRICAL RECORDING INSTRUMENT. Lewis T. Robinson, Schenectady, N. Y.
- 882,602. CONTROLLING-SWITCH. Harold E. White, Schenectady, N. Y.
- 882,606. INDUCTION-MOTOR CONTROL. Ernst F. W. Alexanderson, Schenectady, N. Y.
- 882,607. MAGNETIC CLUTCH. Robert Anderson, Schenectady, N. Y.
- 882,610. ADJUSTABLE ELECTRICAL RESISTANCE. Frederick O. Ball, Plainfield, N. J.
- 882,639. CONTROLLING SYSTEM FOR ELECTRIC MOTORS. Henry D. James, Pittsburg, Pa.
- 882,658. CONTROL SYSTEM FOR ELECTRIC MOTORS. Hermon L. Van Valkenburg, Pittsburg, Pa.
- 882,673. LIGHTNING-ARRESTER. Walter T. Goddard, Victor, N. Y.
- 882,681. ELECTROMAGNETIC TOY ENGINE. Harry G. Hawekotte and Henry W. Klausman, Indianapolis, Ind.
- 882,682. COMMUTATOR FOR POLYPHASE CURRENTS. Alexander Heyland, Brussels Belgium.
- 882,687. ELECTRICAL CONTROL SYSTEM. Henry D. James, Pittsburg, Pa.
- 882,695. SYSTEM FOR AUTOMATICALLY STOPPING CARS OR TRAINS. Edward E. Kleinschmidt, New York, N. Y.
- 882,699. ELECTRICAL RECEPTACLE FOR PLANTS. Harry S. Latshaw, Jersey Shore, Pa.
- 882,717. COMBINED TROLLEY-WHEEL AND SLEET-CUTTER. Edmund M. Schollenberger, Chicago, Ill.
- 882,733. ELECTRIC FURNACE. Edwin Appleby, Chicago, Ill.
- 882,744. SIGNALING DEVICE. Spencer C. Cart, Spokane, Wash.
- 882,752. LETTER-BOX ALARM AND INDICATOR. Oscar F. Erickson, Berkeley, and Richard H. Bradshaw, Oakland, Cal.
- 882,753. TROLLEY-WHEEL. Daniel D. Grant, Pittsfield, Mass.
- 882,758. FIRE-ALARM SYSTEM. Henry H. Hillier, Pasadena, Cal.
- 882,788. ELECTRIC FURNACE. Albert L. Marsh, Lake Bluff, Ill.
- 882,803. INSULATOR. Leonard W. Storrer, San Francisco, Cal.
- 882,833. TROLLEY-HARP. Frank M. Mudler, Pittsburg, Pa.
- 882,848. SNAP-SWITCH. William M. Scott and James H. Wyatt, Philadelphia, Pa.
- 882,857. SIGN. Edgar B. Wolfe, Newark, N. J.
- 882,872. SYSTEM OF ELECTRICAL DISTRIBUTION. Rufus N. Chamberlain, Depew, N. Y.
- 882,876. SPARK-TIMING APPARATUS. Charles C. Dodge, Wollaston, Mass.

Laboratory Contest

The accompanying photograph is awarded the prize of Three (3) Dollars for this month's Electrical Laboratory Contest.

Numerous photographs were received, but only very few were clear enough for reproduction. From these Mr. Kimball's was selected, being the most interesting.

Photographs to be used in this contest should be as clear and sharp as feasible; it is impossible to reproduce a "hazy" or over-exposed as well as under-exposed photograph. Contestants will please bear this in mind when sending in pictures.



YOUNG ELECTRICAL EXPERT.

Mr. Irving Kimball, a young electrical expert and inventor of Boston, Mass., has recently perfected some valuable and highly important inventions in the electrical line.

He has made a scientific study of the electrical transmission and reproduction of sound, and his improved methods of reproducing music have attracted considerable attention.

His "VITAPHONE," a combined motion picture and sound-reproducing device, is not far from perfection.

The original model of his "MOTOR-PYROGRAPH," an automatic electrically operated pyrograph or wood-burning machine, works to perfection.

The illustration herewith shows Mr. Kimball at his laboratory desk, and here he can usually be found long after the clock has passed the midnight hour.

This photo was taken by Mr. Kimball himself with an automatic electric flashlight of his own invention.

- 882,892. ELECTRICAL PROTECTIVE APPARATUS. James A. Kenny, Chicago, Ill.
- 882,966. TROLLEY. Henry C. Reynolds, Portersville, Cal.
- 882,990. RESISTANCE-UNIT. Lawrence E. Barringier, Schenectady, N. Y.
- 883,007. ALTERNATING-CURRENT REGULATOR. Augustine R. Everest, Rugby, England.
- 883,008. THERMOSTAT. Charles J. Fox, London, England.
- 883,013. VIBRATOR. Andrew G. Gray, St. John, New Brunswick, Canada.
- 883,029. ENGINE-STOP. Vernon J. King, Lorain, Ohio.
- 883,030. VAPOR ELECTRIC APPARATUS. Osias O. Krub, Schenectady, N. Y.
- 883,043. DYNAMO-ELECTRIC MACHINE. John P. Nikonow, Pittsburg, Pa.
- 883,059. ELECTRICALLY-OPERATED SWITCH. Henry F. Starrett, Milwaukee, Wis.
- 883,062. STRAIN-RELIEVING ATTACHMENT FOR TELEGRAPH-KEYS. William H. Teachworth, Waxahachie, Tex.
- 883,078. CONTROLLER FOR ELECTRIC MOTORS. Thomas E. Barnum, Milwaukee, Wis.
- 883,088. TELEPHONE INSTRUMENT. Clifford E. Cole, Birmingham, Ala.
- 883,093. DIVIDED-CENTRAL TELEPHONE SYSTEM. William W. Dean, Chicago, Ill.
- 883,110. ELECTRIC FURNACE. Herman L. Hartenstein, Constantine, Mich.
- 883,114. VAPOR ELECTRIC APPARATUS. Osias O. Krub, Schenectady, N. Y.
- 883,150. ACTUATING MECHANISM FOR ELECTRIC SWITCHES. Harry B. Snell, Toledo, Ohio.
- 883,170. ELECTRODE FOR THE RECOVERY OF METALS FROM SOLUTIONS BY ELECTROLYSIS. Samuel B. Christy, Berkeley, Cal.
- 883,181. ELECTRIC STREET-RAILWAY SWITCH. John P. Dowd and Thomas P. Dowd, Cedar Rapids, Iowa.
- 883,195. SYSTEM OF DISTRIBUTION. David Hall, Norwood, Ohio.
- 883,200. CONTROLLER FOR ELECTRIC MOTORS. Henry D. James, Pittsburg, Pa.
- 883,201. TERMINAL CONNECTOR. Harry T. Johnson, New York, N. Y.
- 883,217. AUTOMATICALLY-TRIPPING TROLLEY-POLE MECHANISM. Thomas H. Mars, Chicago, Ill.
- 883,225. COUPLING APPARATUS FOR ELECTRIC CIRCUITS. Nicholas F. Niederlander, St. Louis, Mo.
- 883,227. INSULATOR. Edward F. Padden, Chicago, Ill.
- 883,242. ATTACHMENT FOR TROLLEY-HARPS. William F. Savage, Columbus, Ohio.
- 883,246, 883,247, 883,248. DYNAMO-ELECTRIC MACHINE. Robert Siegfried, Pittsburg, Pa.
- 883,272. COMBINED FUSED CONNECTOR AND LIGHTNING-ARRESTER FOR ELECTRIC WIRES. Frederick C. Woods, Galesburg, Ill.
- 883,273. TIME-SWITCH. Charles E. Avery, Jersey City, N. J.
- 883,276. ELECTROMAGNETIC MOTOR. Arthur H. Beard, Memphis, Tenn.
- 883,280. LIGHTNING-ARRESTER. Millard Berry, Fayetteville, Ark.
- 883,303. SECURITY LIGHTNING-ARRESTER. William E. Drake, Grand Island, Neb.
- 883,308. EGG-TESTING DEVICE. Frank W. Gaylor, White Plains, N. Y.
- 883,310. TROLLEY-HARP. Edward J. Harrison, South Bend, Ind.
- 883,311. ELECTRICAL SMELTING-FURNACE. Karl A. F. Hirth, Christiana, Norway.
- 883,346. INDUCTOR ELECTRIC GENERATOR. Parrell Rabbidge, Neutral Bay, near Sydney, New South Wales, Australia.
- 883,350. COMBINATION SIGNAL AND TRAIN-STOPPING APPARATUS. Alfred L. Ruthven, Topeka, Kans.
- 883,366. ELECTRIC SWITCH. Arthur L. White, Cresco, Iowa.
- 883,389. SWITCH-CLIP. John Clay, New York, N. Y.
- 883,397. INSULATOR. Walter T. Goddard and John S. Lapp, Victor, N. Y.
- 883,409. SECTIONAL OUTLET-CONDUIT. John L. Kruger, New York, N. Y.
- 883,416. ELECTRIC ALARM FOR LOCKS. Frank M. Merrill, Los Angeles, Cal.
- 883,447. CALL-BOX. Henry S. Bullock, Jr., New York, N. Y.
- 883,484. AMUSEMENT DEVICE. Herbert N. Ridgeway, Boston, Mass.
- 883,490. WATER-HEATER. Adolph W. Schramm, Riverton, N. J.

Wireless Signals to be Flashed Around the Globe

(Paris Correspondent of "MODERN ELECTRICS.")

An interesting proposal has been presented to the Academy des Sciences, by Bouquet de la Grye, the famous French scientist.

This gentleman proposes to equip the Eiffel Tower with such powerful instruments that the exact time according to Paris or Greenwich can be flashed to every vessel afloat in the world, no matter what its position may be.

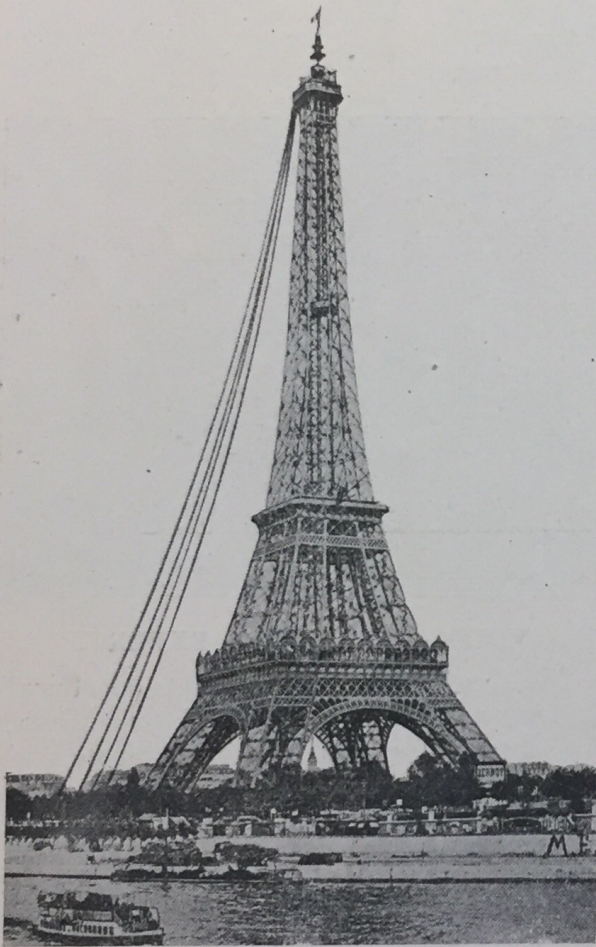

By prearranged signals either at noon or midnight the time could be indicated, which would enable the ships to learn the exact longitude without the trouble to take observations by the sun.

Trials to this effect have already been made. It is now a comparatively easy matter for Paris to keep up communication with all vessels equipped with wireless in the Mediterranean and also part of the Atlantic Ocean.

Simon Newcomb, the famous astronomer of Washington, and Alexander Agassiz of Cambridge, Mass., were quite enthused over the new plan, and do not

doubt that the officials and scientists in the United States will heartily endorse the scheme.

The Eiffel Tower, which has lately been equipped with new, powerful instruments, now furnishes rapid and perfect wireless communication with the army in Marocco; the Government has nothing but praise for the system and greatly encourages the new art.

From the lofty top of the great tower 4 cables are carried down, facing the Avenue de Suffren; the length of these cables is about 910 feet each, forming the highest stationary antennae in the world. These copper cables terminate in several sheds in which the instruments are housed. The officials intend to construct a new, large building on the southwest side of the tower, if the experiments prove successful to warrant the erection of a permanent and costly station.

At the present time experiments are also carried on with wireless telephony, a new system being used. It is claimed that telephone conversation can be carried on up to a distance of 80 kilometres. No details of the system are available at this writing.

Mr. Branly—the real inventor of the filings coherer—has succeeded in directing and manoeuvring government torpedoes by means of wireless; the system is astonishingly simple, and it is claimed that these manoeuvres cannot be interfered with by the enemy,—a claim, if true, will be of the utmost value to the French Government.

Messages by means of the new system have already been sent as far as Lyons and Le Havre; uninterrupted service, however, cannot be maintained so far.

A cursing, excited man may be compared with a sputtering, dancing "trolley wire" which fell to the ground. Both can be easily quietened—but you must know *how* to go at them.—"Fips."

It sounds paradoxical to hear how much hot air a fellow can transmit over the 'phone, especially if there is sleet on the line.—"Fips."

A Relay Working With One Hundred Billionth Ampere

Up to now the most sensitive relay was the Siemens polarized relay, which would close its contacts with about 0.00005 ($\frac{1}{200000}$) amperes.

The new selenium relay invented by Mr. G. Allstrom is said to respond to less than 0.000 000 000 001 (one hundred billionth) ampere. This would make it even more sensitive than a telephone receiver, and experiments have shown that for wireless work it will soon find universal adoption. The instrument was used lately in connection with electrolytic detectors, which were always thought successful only in connection with telephone receivers. Loud, audible signals were never obtained so far with such detectors, but the new Allstrom selenium relay makes it possible to use a sounder or tape register with any kind of detector, no matter how sensitive.

This will come as good news to wireless telegraph experimenters, and we describe herewith the arrangement of the apparatus:

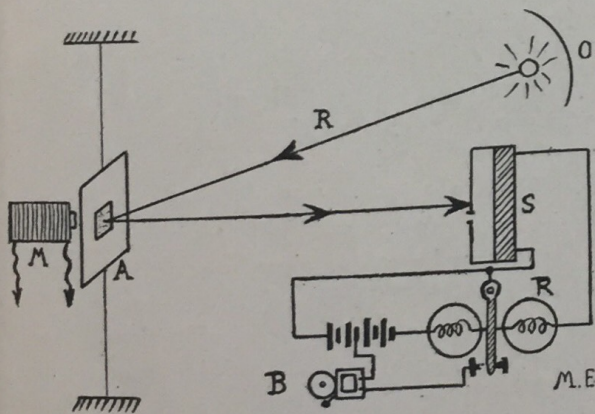

An extremely light piece of sheet iron A, is hung between two platinum wires of the minute diameter of 0.0001 inch. In the centre of the iron sheet a small, very light mirror is cemented. An electromagnet M, which may have a resistance as high as 10,000 ohms, is placed immediately behind the iron foil, so that the magnet core almost touches the iron.

Some distance away a sensitive selenium cell S, is stationed. The cell itself is enclosed in a box, which at the front has a narrow slot. A source of light O, is placed behind and directly over the selenium cell, and the room must of

course be dark. By means of parabolic mirror a beam of light R, is thrown upon the small suspended mirror on A.

This beam is reflected towards S, but as long as the foil A, is motionless, the beam of light does not fall through the slot of S.

However a minute current—such as a wireless wave—passing through the windings of M, will magnetize its core sufficiently to turn the very light mirror on A, and the ray can now fall through the slot of S, which reduces the resistance of the selenium cell. This is sufficient to operate relay R, which in turn will actuate bell B.

With suitable means the oscillations of A can be dampened so that it will return in its original position immediately after the current had passed through M.

AURORA BOREALIS.

Passengers on the Philadelphia Enjoy Nature's Fireworks.

Passengers who arrived a few weeks ago on the American liner Philadelphia from Southampton were still discussing when they landed the aurora borealis which they saw one night. From 6 o'clock in the evening, when the sun had set, until daybreak the next morning the entire zenith was alight with a deep red glow, reflected from the giant rays of fiery lights that shot up into the heavens from the north. On every side of the liner there appeared to be huge fires that made the passengers on the promenade deck feel as if they were looking on at the destruction of the world. Toward 10 o'clock the lights were at their brightest, and outlined the officers on the bridge to the passengers.

Captain Arthur Mills, the skipper of the Philadelphia, told the passengers on deck to listen for a dull, booming sound from the north, which always accompanied the aurora borealis when seen so far east in midocean.

Quite a few "short circuits" are necessary to make a successful electrician.—
"Fips."

“Knick-Knacks”

Brews Your Coffee While You Sleep

By M. G. HUGO

If you happen to be a hustler and if you must have your coffee ready five minutes after you wake up, the following arrangement will be welcomed. It is entirely automatic and when well constructed, never fails to work:

Attach a wire to the inner frame of your alarm clock and another wire to a thin brass strip, which is best glued to the pasteboard dial; it should be arranged in such a way that only the hour hand can touch it. The minute hand must pass over it without touching.

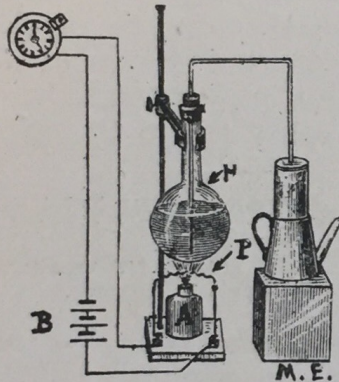

Let us suppose you have to be up by 5 o'clock in the morning. In that case the contact brass strip is glued to the dial at that point, which is reached by the hour hand at 10 minutes *before* five. The alarm itself is set for 5 A. M.

If now at 10 minutes to five the hour hand establishes contact with the brass strip (thereby closing the circuit), Battery B, (4-5 dry cells) will heat the one-inch piece of platinum wire P, (0.008

inch in diameter) to a white heat. This heat is sufficient to light the small alcohol lamp A, and in about five minutes the water in the glass flask H, will commence to boil.

This glass flask has a soft rubber stopper into which fits a glass tube bent into two right angles, as shown in sketch. It is necessary that the rubber stopper fits tight in the flask and that the glass tube fits the stopper snugly.

On a block of wood a coffee machine is placed which contains the usual amount of ground coffee. Instead of its cover, a circular piece of wood is provided, through which the other free leg of the glass tube passes.

Now as soon as the water commences to boil, enough pressure is created to drive a certain amount of boiling water through the tubing in the coffee pot, and if in five more minutes the alarm goes off and you wake up, all you will have to do is to reach over and pour out a cup of delicious hot coffee.

It is to be recommended to keep the arrangement some distance away from you—not because there is danger (an explosion or fire, etc., is impossible)—but because if you drink your coffee in bed, you might go back to sleep!

It is understood that you will have to blow out the flame of the alcohol lamp as soon as you wake up; also the battery must be disconnected, or else the alcohol lamp will be lighted anew at 5 P. M. of the same day.

Technical Notes

NON-CORROSIVE SOLDERING FLUX,

No. 1.

Add C. P. zinc chloride to 95° pure grain alcohol (6 to 8 ounces) to saturation and shake thoroughly; let stand until the zinc settles and pour off 4 Fl. ounces of the clear solution.

Then add 2 Fl. oz. glycerine and 14 Fl. oz. pure grain alcohol (95°), and shake thoroughly.

No. 2.

Borax 1 oz., sal-ammoniac 1¼ ozs., rosin 1¾ ozs., powdered and mixed; scrap zinc and cut fine, 16 ozs., commercial muriatic acid, 32 Fl. ozs. Mix all in an earthen jar and let stand for 10 hours. Then add rainwater 1 quart; stir thoroughly and let stand another 10 hours. Then add glycerine 1 Fl. oz. and grain alcohol 1½ Fl. ozs. Strain through cotton and filter through sand or filter paper. This is good for fluxing any kind of metals.

Contributed by W. S. PRESTON, Winchester, Ind.



Queries and questions pertaining to the electrical arts addressed to this department will be published free of charge. Only answers to inquiries of general interest will be published here for the benefit of all readers. Common questions will be promptly answered by mail.

On account of the large amount of inquiries received, it may not be possible to print all the answers in any one issue, as each has to take its turn. Correspondents should bear this in mind when writing, as all questions will be answered either by mail or in this department.

If a quick reply is wanted by mail, a charge of 15 cents is made for each question. Special information requiring a large amount of calculation and labor cannot be furnished without remuneration. THE ORACLE has no fixed rate for such work, but will inform the correspondent promptly as to the charges involved.

Name and address must always be given in all letters. When writing only one side of question sheet must be used; not more than five questions answered at one time. No attention paid to letters not observing above rules.

If you want anything electrical and don't know where to get it, THE ORACLE will give you such information free.

TO CHANGE DIRECT CURRENT FAN INTO AN ALTERNATING ONE.

(14.) HERBERT BOWLER, San Diego, Cal., writes:

I have a direct current fan motor and wish to know how it can be changed into alternating current.

A.—Yes, you might try, although we do not vouch that you will have success. It will be necessary to rewind the armature with one continuous wire; also the commutator must be eliminated. On the shaft two insulated brass or copper rings are fastened on fiber rings, and the two wires from the armature are connected to the metal rings. Two metal springs or brushes take off the current from the rings. One of the springs is connected to the field, making the motor series wound.

PLATINUM CONTACTS FOR ELECTRIC WHISTLE.

(15.) R. SYLVESTER, Bradford, Mass., asks: Would the wire used to connect with the filaments of an incandescent light be suitable for the contacts of the electric whistle described in the April number? Where can I buy platinum foil?

A.—No. You must use platinum foil. Same is obtained from electrical supply houses, which you will find in our advertising columns.

MOTOR COMMUTATOR "GREASES" UP.

(16.) JOHN ROAKE, Bayonne, N. J., writes:

My motor takes 5 volts, 1/2 ampere. It has woven wire brushes. Armature is drum type, 6 slots. Every time I run it the commutator gets filled with a kind of grease and stops, the circuit between the

brushes can be cleaned every five minutes, but the grease will come again. Please advise.

A.—You are using too much oil on the bearings. The fast revolution of the armature sucks up every drop and gums up the commutator. Use a little vaseline on bearings; oil is suitable only for large motors having well protected bearings.

CHARGING STORAGE BATTERIES.

(17.) WALLACE BLANCHARD, Manlius, N. Y., asks:

- 1.—Will a dynamo giving eight volts, one ampere charge three storage cells?
- 2.—How long would it take to charge three cells, each of ten hours capacity, with four Edison batteries, type "B.B."?
- 3.—Where can I get some paraffin paper to make a condenser with?
- 4.—Why is it that a "Wonder" Alternator will not run on 104 volt alternating current in series with a lamp?

A. 1.—Yes, although it will take about 10-12 hours steady run of dynamo to fully charge ten A. H. cells.

A. 2.—About 10-12 hours, but the storage cells must then be connected in parallel. Charging in series would not do, because three storage batteries when fully charged read 7 1/2 volts, while 4 Edison batteries only give 3.6 volts when fresh. Charge your cells with 3 amperes.

A. 3.—There is paraffined paper on the market, but not for the purpose you intend to use it for. You will have to make it yourself. Melt some paraffine in an iron vessel over a very small flame. When hot enough, dip your paper, which should be fairly heavy (letter paper), in the paraffine and keep it in the fluid till

the bubbles stop appearing. Take the paper out and hang up to dry.

A. 4.—You will need more current to run the alternator. A 16 C. P. lamp, which we presume you are using, only allows $\frac{1}{2}$ ampere to pass. You need about 2 amperes; connect 4 lamps (16 C. P.) in bank as per sketch. This will make it work.

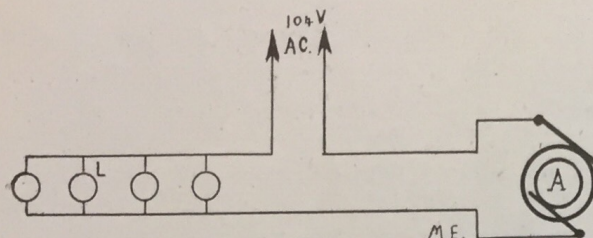

WIRE FOR SPARK COIL.

(18.) HARRY C. THOMPSON, Ludlow, Vt., writes:

1.—I have about a quarter of a pound of No. 36 double cotton covered magnet wire and plenty of such as the sample enclosed. If I can make a spark coil of this amount of wire, what would be the best dimensions, length, diameter of core, number of layers in primary?

2.—Kindly explain why zinc chloride is used in recharging dry batteries instead of sal ammoniac?

A. 1.—Sample of wire submitted is single cotton covered magnet wire No. 14 S. W. G. It is a good deal too heavy for a small coil. We recommend N. 18 or 16 D. C. C. well paraffined wire. You can undoubtedly use your No. 36 wire, however $\frac{1}{4}$ lb. will hardly give much over $\frac{1}{4}$ inch spark. We refer you to our well written book, "Induction Coils and How To Make Same," by Marshall. Price, postpaid, 25 cents.

A. 2.—Chloride of zinc has the property of being hygroscopic, which means that it will collect the moisture from the air. It will consequently help to keep any renewed dry cell from drying up too fast. Besides this chemical, as an exciting electrolyte (in connection with chloride of ammonium, sal ammoniac) greatly reduces the internal resistance of the cell.

PULLEY FOR MOTOR.

(19.) ALEX A. AARONS, N. Y., asks:

1.—I have a 110 volt direct current fan motor. How can I use this on a 110 volt alternating current?

2.—What size pulley must be put on a one-eighth ($\frac{1}{8}$) horse power motor to give 2,200 revolutions per minute?

A. 1.—We refer you to inquiry No. 1 in this issue.

A. 2.—We cannot tell unless you state how many revolutions your motor makes per minute.

WHAT SPARK LENGTH WOULD THE COIL FURNISH?

(20.) CLARENCE M. KRUG, Beatty, Pa., writes:

What size spark would a coil give, the primary being wound with 125 feet of No. 18 wire and the secondary with 1,000 feet of No. 25 wire?

A.—A coil made with a quantity of wire as per above directions will hardly give a jump spark. In the first place, No. 25 wire is entirely too heavy. Even long distance wireless coils are hardly ever wound with as thick a wire as No. 30. Furthermore, 1,000 feet of wire in the secondary is a good deal too little. Use about $\frac{3}{4}$ lb. No. 36 D. C. C. wire and your spark coil will give about $\frac{3}{4}$ -1" spark. The primary does not need quite as much wire as you state. About 50 feet will be sufficient.

GRAVITY CELLS FOR LIGHTING LAMPS.

(21.) STEPHEN F. RUSNACK, Pana, Ill., writes:

1.—Please let me know whether gravity cells (blue stone cells) can be used to light small incandescent lamps, and whether they can be used in closed circuit?

2.—What is used to keep the litharge and red lead from dissolving after the plates of a home-made storage battery are formed? Or what would be best to retain the same in the holes?

A. 1.—Yes, but you cannot light more than 3-5 small incandescent lamps, as the high internal resistance of gravity cells allows only very little current to pass. Even large cells of this type hardly ever give more than 1-1 $\frac{1}{2}$ amperes. By using the new tantalum filament lamp gravity cells can be used to good advantage; such lamps use only about $\frac{1}{4}$ ampere, against $\frac{3}{4}$ -1 ampere of the common carbon filament lamp. In other words, 4 tantalum lamps do not use more current than one carbon type lamp. Gravity cells are of course used in closed circuit work. They are hardly ever used for any other purpose than just this one.

A. 2.—Nothing is used to keep litharge or red lead from dissolving in storage battery plates. The two named chemi-

cals in this respect act exactly like portland cement. As soon as the cement has set—although water was used to prepare it—water cannot dissolve it afterwards. It is the same with red lead or litharge. If the right fluid was used to make the paste, viz.: sulphuric acid, glycerine, liquid ammonia, etc., etc., the resulting cement will not dissolve any more, once it has set. One of the best liquids to use for pasting either red lead or litharge is made by mixing 10 parts of liquid ammonia, 26°, with 2 parts of glycerine. The resulting plates are hard and sound and do not “shed” when in use. To obtain a perfect plate it must be porous. To that effect, before pasting, mix the red lead or litharge with 2-3% fine ground sulphate of ammonium. The resulting paste must be worked quick, as it hardens soon; use as little liquid as possible. The paste should never flow, it must be stiff and rather hard.

WIRE FOR ONE-INCH SPARK COIL.

(22.) ARTHUR H. BLAKE, Philadelphia, Pa., asks:

1.—How many pounds or fraction thereof of No. 34 (bare) magnet wire would be required for a 1" spark coil, whose core is 7/8" x 7", having 1/2 lb. No. 14 magnet wire in primary?

2.—What is meant by tinned copper wire?

3.—Does the Electro Importing Co., New York, carry No. 34 bare magnet wire? If not please send me the name of some other reliable firm who does.

4.—Also, what firms sell carbon, such as is used in dynamo brushes, to be used for a microphone detector.

A. 1.—About 1 to 1 1/8 lbs. will do, although we do not recommend to use bare wire. Use D. C. C., it is less risky.

A. 2.—Plated or covered with tin. It is used to give the wire a better finish and to keep it from oxydizing (blackening).

A. 3.—Yes.

A. 4.—Eastern Carbon Works, Jersey City, N. J., can furnish you with such carbons, or carbons of any description and shape.

WIRELESS QUERIES.

(23.) M. G. VAN AUKEN, Ames, Ia., writes:

1.—(a) Why is a variable resistance sometimes used in the circuit between the relay and the coherer?

(b) Is not a resistance sometimes introduced in the circuit between the aerial and coherer also?

2.—Where a telephone receiver is used to take wireless messages how is the receiving party “called up”?

3.—Is not the telephone receiver and electrolytic “coherer” now regarded as more efficient than the filings coherer, relay, sounder, decoherer, etc.?

4.—What is the address of some company where I may purchase tubes of celluloid for wireless coherers?

5.—Does a Leyden jar (condenser) when connected to the secondary terminals of a spark coil increase or decrease its sending qualities? I notice that when I connect my jar with the coil the spark becomes much fatter and more vigorous.

A. 1.—(a) This is hardly ever used now, and we doubt if much benefit could be derived from such an arrangement. Fixed resistances and choke coils are used sometimes.

(b) Yes. You probably have in mind the regular tuning coil to vary amount of inductance.

A. 2.—The answer to this is found on page 60 of this issue.

A. 3.—Yes, the combination is sometimes 100% more sensitive and equally efficient than the filings type.

A. 4.—The Electro Importing Co., of New York City, can undoubtedly furnish you with such tubing.

A. 5.—The sending distance is increased a good deal, as the oscillations of condenser discharge are very persistent and do not die away as rapidly as the direct discharge of a coil alone. Tuned circuits must be used, however, on both sending and receiving stations.

BROOKLYN NAVY YARD'S AERIAL.

(24.) C. A. BILMS, Ocean Grove, N. J., asks:

1.—Is there any difference in the sending and receiving range of an aerial wire? That is, could, say, a 50-foot aerial send a greater distance than it could receive, or vice versa?

2.—How are the letters Ä . . . , Ch . . . , É . . . , Ö . . . , and Û . . . of the Continental code used?

3.—What is the height of the aerial used at the Brooklyn Navy Yard wireless station?

4.—And the height of the aerial (from the water line) on coastwise steamers,

such as those of the Clyde and Ward lines?

A. 1.—Yes. If your receiving apparatus are sensitive enough, nothing prevents you to receive messages 1,000 miles away. If, on the other hand, you have only a 1-inch spark coil with which to transmit, the sending distance at best will only be about 1-1½ miles. The range of a wireless station does not depend so much on the aerial as on the efficiency of the instruments.

A. 2.—Ä, Ö and Ü form part of the German alphabet. É forms part of the French alphabet (e accent aigu)—sharp accent—as in café. Ch is used a good deal in the French language. In this country, when transmitting telegrams the letters are used separately, viz.: C-h.

A. 3.—180 feet.

A. 4.—65-85 feet.

DATA ON ONE-INCH SPARK COIL.

(25.) MAGEE ADAMS, Milford, O., asks:

1.—If a wireless receiving station is equipped with a receiver using a telephone receiver, is there any way to call, that is, ring a bell or the like?

2.—What is the best and most efficient type of antennae for a small wireless plant using a microphone or electrolytic detector?

3.—Is there any danger of the secondary wire in a spark coil burning out, except on an overloaded primary?

4.—Please give data for a spark coil that will give a spark 1" long and as big around as a lead pencil or larger, that would not use wire finer than No. 30 B. & S. D. C. C. in the secondary.

A. 1.—We refer you to "Oracle," query No. 23, in this issue.

A. 2.—A mast about 40-50 feet high, carrying glass insulators, on which a bare copper wire, No. 14 B. & S. gauge, is led down.

A. 3.—Yes. If the coil works continuously, by having the secondary leads short circuited, or if the coil is worked a long time by having the secondary circuit "open."

A. 4.—Core made of 150-200 pieces well annealed iron wires, 6 inches long, No. 18 B. & S. Over this core wind paraffined paper, or, better, use a hard rubber tube, over which wind 75-80 feet

D. C. C. paraffined magnet wire, No. 15. For the secondary use 1½-2 No. 30 D. C. C., or, better, S. S. magnet wire.

THE DYNAMOPHONE.

(Continued from Page 45.)

Every time the circuit is closed a series of sparks will jump across the balls at S, creating oscillations. The oscillations, traveling through the ether, arrive at the receiving station, where they impinge on the antennæ A and operate the coherer O through relay R. The decoherer D is also shown. Relay coherer and decoherer are all operated by a single dry cell L. This is the same circuit as in my "Telimco" wireless system. Relay R' has in addition two stationary contacts T and T', which, when the armature Z closes, complete another circuit, as, for instance, through a small motor P, an incandescent light, etc.

As long as words are spoken in the transmitter M, oscillations will be set up in S and the receiving station will work continuously until the voice at M stops. Motor P will, of course, be kept in motion only as long as the voice falls into M.

WIRELESS TELEGRAPH ODDITIES.

(Continued from Page 56)

and Clifden, and between Glace Bay and Montreal.

"I find, however, that probably the greatest ignorance prevails in regard to what is termed 'tapping,' or intercepting wireless messages. No telegraph system is secret. The contents of every telegram are known to every operator who handles it.

"Nevertheless, there are penalties attached to the tapping of a telegraph wire, and it ought to be as well known that, since the passing of the Wireless Telegraphy act in England, there are penalties involved if any wireless stations are erected or worked without the consent of the Postmaster-General.

"In conclusion I may say that I am very confident that it is only a question of time, and not a very long time before wireless telegraphy over great distances, possibly round the world, will become an indispensable aid to commerce and civilization."

Paper read before the Royal Institution.

ELECTRICAL PATENTS

(Continued from Page 63.)

- 883,530. TELEGRAPH-REPEATER. Stephen D. Field, Stockbridge, Mass.
- 883,539. ANNUNCIATOR. Stephen J. Heinrich, Bellevue, Pa.
- 883,549. FITTING FOR ELECTRIC CONDUITS. Allan R. Lakin, New York, N. Y.
- 883,550. BRUSH AND BRUSH-HOLDER FOR DYNAMO-ELECTRIC MACHINES. Frederick H. Loring, London, England.
- 883,589. ELECTROLYTIC PRODUCTION OF PURE TIN. Adolphe J. M. Thiroit, Bourges, France.
- 883,594, 883,595. PROCESS OF OBTAINING METALS AND ALLOYS BY REDUCTION. Emilien Viel, Rennes, France.
- 883,613. LIGHTNING-ARRESTER. Henley V. Bastin, Lancaster, Ky.
- 883,625. CABLE TERMINAL. Frank B. Cook, Chicago, Ill.
- 883,626. ELECTRICAL LINE-PROTECTOR. Frank B. Cook, Chicago, Ill.
- 883,646. SAFETY DEVICE FOR ELECTRIC POINT SHIFTING, SIGNALING, LOCKING, AND SWITCHING APPARATUS. Lorenz Kottmair, Munich, and Rudolf Zwack, Nordendorf, near Augsburg, Germany.
- 883,651. ELECTROLYTIC PRODUCTION OF CHROMIC ACID. Max Le Blanc, Karlruhe, Germany.
- 883,701. SWITCHING DEVICE. James A. Duffy and Oscar Irwin, Pittsburg, Pa.
- 883,723, 883,724. ELECTRIC TRANSMISSION OF INTELLIGENCE. Isidor Kitse, Philadelphia, Pa.
- 883,737. TALKING-SIGN. Lucius R. Paige, Worcester, Mass.
- 883,760. SYSTEM OF DISTRIBUTION. Lewis L. Tatum, Norwood, Ohio.
- 883,777. CLUSTER-LAMP SOCKET. Reuben B. Benjamin, Chicago, Ill.
- 883,811. TELEPHONE-SUPPORT. Otto Kraus, New York, N. Y.
- 883,822. DYNAMO-ELECTRIC MACHINERY. Chas. A. Parsons, Newcastle-upon-Tyne, England.
- 883,823. INSULATOR-SUPPORT. Charles L. Pierce, Jr., Elkhart, Ind.
- 883,846. ELECTRICAL MULTIPLE INFLUENCE OR CONDENSER MACHINE. Heinrich Wommelsdorf, Charlottenburg, Germany.
- 883,851. IGNITION MECHANISM FOR INTERNAL-COMBUSTION ENGINES. Theodorus S. Bailey and Frank T. Cable, Quincy, Mass.
- 883,865. ADVERTISING APPARATUS. Henry Dahn, Edgewater, N. J., and Frederick Becker, New York, N. Y.
- 883,919. REACTIVE COIL. Charles P. Steinmetz, Schenectady, N. Y.
- 883,924. ARC-LAMP ELECTRODE. William S. Weedon, Schenectady, N. Y.
- 883,943. REVERSE-CURRENT CIRCUIT-BREAKER. Charles E. Eveleth, Schenectady, N. Y.
- 883,944. ELECTRIC LIGHTING. Walter C. Fish, Lynn, Mass.
- 883,956. MOTOR-STARTER. Albert J. Horton, White Plains, N. Y.
- 883,961. ELECTROMETALLURGICAL PROCESS FOR EXTRACTING COPPER FROM ITS ORES. Lucien Jumau, Paris, France.
- 883,964. SIGNALING SYSTEM FOR ELECTRIC RAILWAYS. Harry N. Latey, New York, N. Y.
- 883,992. ELECTRIC TIME-INDICATING DEVICE. William F. Wentz, New York, N. Y.
- 884,002. CONTROLLER FOR ELECTRIC MOTORS. Thomas E. Barnum and Henry H. Cutler, Milwaukee, Wis.
- 884,007. TRAIN CONTROL FOR ELECTRICAL ACCUMULATOR-LOCOMOTIVES. Otto Bohm, Berlin, Germany.
- 884,015. ELECTROLYTIC CELL. Albert S. Gray, Chicago, Ill.
- 884,018. INCUBATOR-ALARM. Fremont R. Harris, Kenmare, N. D.
- 884,021. APPARATUS FOR MAKING COPPER. Marcel A. Jullien and Emile L. Dossolle, Levallois-Perret, France.
- 884,028. ACCUMULATOR-PLATE. Michail Margulis, Odessa, Russia.
- 884,047. AUTOMATIC ALARM SYSTEM. John E. Shepherd, Chicago, Ill.
- 884,066. AUTOMATIC ALTERNATING-CURRENT CONTACT APPARATUS. Charles E. L. Brown, Baden, Switzerland.
- 884,070. SPACE TELEGRAPHY. Sewall Cabot, Mass.
- 884,074. ATTACHMENT FOR TROLLEY-POLE CLAMPS. Curtis W. Clark and Charles E. Yingling, Eaton, Ind.

Wireless Telegraph Outfit

GREATEST INVENTION OF THE AGE.

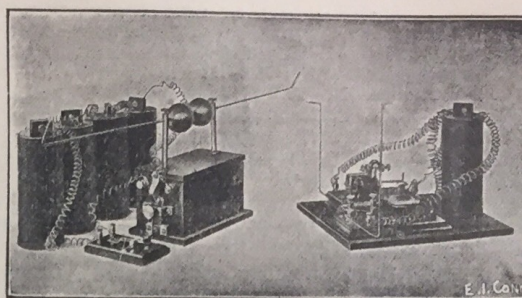

Not a toy. A scientific, high grade apparatus. Will work up to one mile. Comprises: Powerful 1-inch Spark Coil, Oscillator Balls, Key, Coherer and Decoherer, 75 Ohm. Relay, Sending and Receiving Wires, etc., etc. Guaranteed in every respect. Price remarkably low.

CARRIED IN STOCK IN SAN FRANCISCO

LEVY ELECTRIC CO.

SAN FRANCISCO, - - - - - CAL.

When writing please mention "Modern Electrics."

Electrical Novelties?

Yes, we have them. Drop us a line if you wish to get acquainted with our Geissler Tubes, Static Machines, Reflectors, Wireless Goods, etc., etc. A two-cent stamp brings a Catalogue that will interest you. Write at once

432 ST. CLAIR STREET

J. J. DUCK - - - TOLEDO, O.

When writing please mention "Modern Electrics."

AN ELECTRIC SUN ALARM.

(Continued from Page 53)

As long as no light rays fall on the cell relay, R, is not capable to close contacts, G, as the resistance of C is too high.

In the morning, however, at sunrise enough diffused light reaches the cell to lower its resistance and if the light has grown strong enough alarm, B, will ring until switch, S, is opened, or until light ceases falling on the cell.

This arrangement will be found to work quite satisfactory and is very reliable, if the instruments are good ones and well adjusted.

It is very seldom that the alarm will not operate faithfully; the writer knows of only one instance, and that was on a very dark, rainy morning when not enough diffused light reached the cell.

It is, of course, not necessary that the sun's rays fall directly on the selenium; diffused light will work the cell quite satisfactory.

- 884,075. ELECTRODEPOSITION OF IRON. Sheppard O. Cowper-Coles, London, England.
- 884,076. SPACE TELEGRAPHY. Ernest R. Cram, Cambridge, Mass.
- 884,102. ELECTRIC-LAMP SOCKET. Mortimer Norden, New York, N. Y.
- 884,106, 884,107, 884,108, 884,109, 884,110. SPACE TELEGRAPHY. John S. Stone, Cambridge, Mass.
- 884,116. ELECTRICAL-IGNITION SPARK-COIL FOR GAS OR VAPOR ENGINES. Edward Q. Williams, Syracuse, N. Y.
- 884,121. AUTOMATIC ELECTRIC ALARM FOR BEDS TO BE OCCUPIED BY PATIENTS, SUCH AS HOSPITAL-BEDS. Frank Apold, Philadelphia, Pa.
- 884,124. PROCESS FOR THE ELECTROLYSIS OF FLUID SALTS OR COMPOUNDS. Henry S. Blackmore, Mount Vernon, N. Y.
- 884,129. ELECTRIC SIGNAL. Arthur J. Cleveland, and Frank S. Brown, Minneapolis, Kans.
- 884,130. ELECTRIC TIME-SWITCH. James J. Coachman, London, England.
- 884,142. INSULATOR. Ernest J. Foreman, Trinidad, Colo.
- 884,158. SYSTEM OF AUTOMATIC BLOCK-SIGNALING FOR ELECTRIC RAILWAYS. Winthrop K. Howe, Buffalo, N. Y.
- 884,170. THIRD-RAIL ELECTRIC-RAILWAY SYSTEM. Charles Kozesnik, New York, N. Y.
- 884,224. RAILWAY-SIGNAL. John S. Sims, Longbeach, Cal., assignor of one-half to Edward Richard Millar, Longbeach, Cal.
- 884,235. RECEIVER FOR TELEPHONES. Louis Steinberger, New York, N. Y.
- 884,247. COIN-CONTROLLED APPARATUS. David Wedgewood, Peterboro, Ontario, Canada.
- 884,264. STORAGE BATTERY. George A. Carpenter, New York, N. Y., administratrix of Hiram Henry Carpenter.
- 884,271. ELECTRIC-LIGHT SOCKET. Franz Frankowski, North Braddock, Pa.
- 884,296. ELECTRIC CURLING-IRON. Clara A. Rickards, Portland, Ore.
- 883,312. ELECTRICAL CONNECTOR. James L. Carnall, New York, N. Y.
- 884,343. ELECTRIC WATER-HEATER. Herbert N. Roche, San Francisco, Cal.
- 884,353. ELECTRIC SWITCH. Herbert H. Berry, Enfield, England.
- 884,358. ELECTRICALLY-SYNCHRONIZED TIME-MEASURING INSTRUMENT. Bahne Bonnicksen, Coventry, and Frederick A. Chandler, Leamington, England.
- 884,367. ELECTRICAL WATER-HEATER. Edward J. Condon, New York, N. Y.
- 884,381. TELEGRAPH-TRANSMITTER. Mark S. Haling, Weaver, Minn.
- 884,397. OVERHEAD TROLLEY. Allen P. Lord and Nathaniel Wilkins, Bradford, Pa.
- 884,424. ELECTRICAL FLUID-HEATER. Mark T. Seymour, Bemus Point, and Alton W. Ball, Stowe, N. Y.
- 884,441. COIN-CONTROLLED APPARATUS. John A. Weser, New York, N. Y.
- 884,456. INSULATING COMPOUND. Nathan Booth, Alexandria, Ind.
- 884,458. ELECTRIC-CURRENT REGULATOR. Arthur W. Brice, Rochester, N. Y.
- 884,466. SWITCH-BOX. Thomas J. Cleland, Chicago, Ill.
- 884,470. COIN-COLLECTOR. Edward B. Craft, Chicago, Ill.
- 884,500. TELEPHONE DESK-STAND. Anton M. Knudsen, Chicago, Ill.
- 884,511. SELF-STARTER. Walter O. Lum, Schenectady, N. Y.
- 884,514. AUTOMATIC ELECTRIC SWITCH. Andrew H. Miller, Chesaning, Mich.
- 884,516. MACHINE FOR PRINTING FROM FILMS OR PLATES. Clyde G. Morgan, Mount Vernon, Mo.
- 884,517. CONDUIT ELECTRIC RAILWAY. Lewis W. Musick, Crescent City, Cal.
- 884,519. FUSE-HOLDER FOR ELECTRIC-CIRCUIT CONDUCTORS. Patrick McDonald, Rochester, N. Y.
- 884,540. ELECTRIC HEATER. Elihu Thomson, Swampscott, Mass.
- 884,541. SYSTEM OF CONTROL FOR ELECTRIC MOTORS. Leonard A. Tirrill, Lynn, Mass.
- 884,546. TROLLEY-WHEEL. Frederick G. Walker, Cleveland, Ohio.
- 884,555. REGULATION OF DYNAMO-ELECTRIC MACHINES. Charles E. Barry, Schenectady, N. Y.
- 884,563. PROCESS OF FUSING MATERIALS. Geo. F. Brindley, Niagara Falls, Ontario, Canada.
- 884,568. MACHINE FOR MAKING INCANDESCENT LAMPS. William R. Burrows, Newark, N. J.
- 884,595. CARRIER SYSTEM. Sam H. Libby, Orange, N. J.
- 884,607. TELEPHONE FIRE-ALARM SYSTEM. William S. McLewee, Yardley, Pa.
- 884,622. ELECTRIC RAILWAY-SIGNAL. George A. Stafford, Belcherville, Ira P. Whitaker, Alford, and John L. Lopp, Greenwood, Tex.
- 884,630. TROLLEY POLE AND HEAD. August P. Bauer, Philadelphia, Pa.
- 884,637. TELEPHONE ATTACHMENT. William W. Bythiner, Philadelphia, Pa.
- 884,641. HANGING INSULATOR. Walter G. Clark, New York, N. Y.
- 884,644, 884,645, 884,646. SYSTEM FOR ELECTRIC RAILWAYS. Arthur C. Eastwood, Cleveland, Ohio.
- 884,653. ELECTROLYTIC CELL. George A. Gabriel, New York, N. Y.
- 884,664. DEPOLARIZER FOR GALVANIC BATTERIES. Ernst W. Jungner, Kneippbad, Norrköping, Sweden.
- 884,684. TROLLEY HARP AND WHEEL. Edward D. Rockwell, Bristol, Conn.
- 884,731. ELECTRIC IGNITING DEVICE. Roy E. Hardy, New York, N. Y.
- 884,737, 884,738. SIGNALING SYSTEM. Edward E. Kleinschmidt, New York, N. Y.
- 884,742. ELECTRIC TYPE-WRITER. Joseph Lembke, Sennheim, Germany.
- 884,775. ELECTRIC SWITCH. Adolph R. Swoboda, Louisville, Ky.
- 884,783, 884,784. SIGNAL SYSTEM FOR RAILWAYS. Maximilian G. Voigtlander, Harrison, Ohio.
- 884,825. AUTOMATIC ELECTRIC CROSSING-GATE. Frank G. Layher, Jackson, Mich.
- 884,831. ALTERNATING-CURRENT GENERATOR. Carl A. Lohr, Wilkinsburg, Pa.
- 884,843. MONEY-DRAWER ALARM. Sillus De Costa Newman, Jellico, Tenn.
- 884,919, 884,920. PROCESS FOR MAKING NITROGEN OXIDS FROM AIR. August Grau and Franz Russ, Vienna, Austria-Hungary.
- 884,930. ELECTRODE FOR REVERSIBLE GALVANIC BATTERIES. Ernst W. Jungner, Kneippbad, Norrköping, Sweden.
- 884,969. THERMOSTATIC CIRCUIT-CLOSER. Jay O. Woods, Riverside, Wash.
- 884,973. AUTOMATIC INDICATOR OR THERMOSCOPIC SIGNAL FOR HEATED TOOLS AND VESSELS. James I. Ayer, Cambridge, Mass.
- 884,986, 884,987, 884,988. WIRELESS TELEGRAPHY. Guglielmo Marconi, London, England.
- 885,000, 885,001, 885,002. SWITCH FOR TROLLEYS. Ewan Cameron, Brooklyn, N. Y.

TESTING A MODERN ELECTRIC LOCOMOTIVE.

(Continued from Page 42)

In this way we pass over that part of the test track containing several curves and a slight up grade, which ends about one mile west of the sub-station. Then we enter a straight stretch, ending in a long, well-balasted curve, equal to about 70 degrees of the circumference of a circle, and on the inside of which, close to the track, is the sub-station and barn, and just beyond the crossing. Directly upon leaving the sharper curves the motorman gives his gearless machine (the axles of the drivers are the shafts of the motors around which are the armatures) the entire 660 volts, and we immediately experience an increase in speed. This continues until it reaches about 74 miles per hour, when it strikes the curve, reels gently to one side and settles itself in that position. The motorman pulls the chord of his great compressed air whistle for four long, loud

(Continued on Page 74.)

SPEAKING ARC LIGHTS IN RAILROAD DEPOTS.

The speaking arc lamp has at last found practical use in some of the large German towns.

Most Americans are now so used to the bellowing, howling individual in our large railroad stations, who pretends telling us what the destination of the next train is, that they do not mind his unesthetic roar any more. There are even some people who boast that they can understand every "word" which these train announcers trumpet out, but the poor stranger would much rather hear a dozen Sioux braves howl their war whoops than try to make out where the next train stops first.

Apparently the Germans were the first to realize the importance of having an efficient way to call out trains, and to this effect they first equipped some of Berlin's large depots with extra strong phonograph announcers.

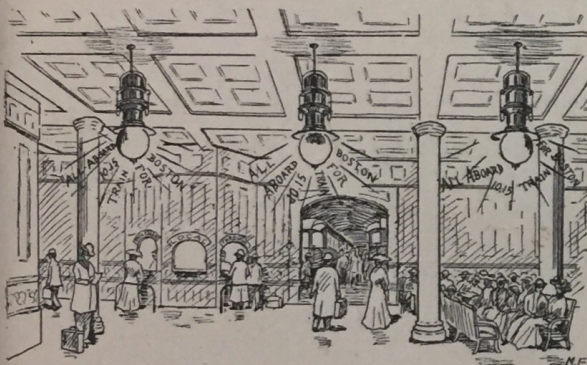

It was found out soon though that these phonographs could be understood only in certain parts of the waiting-rooms; the acoustic properties of the large halls did not seem to be just what they ought to be and the phonographs were sent to the scrap heap.

Next a bright "elektriker" hit upon the idea to use 4-6 speaking arc lights, all of them connected in series. These lamps are scattered over the waiting-rooms and placed so that they give the maximum effect.

An operator talks in a specially designed transmitter in the operating room and it is not necessary at all to exert the voice to obtain best results.

The advantage of the system is that the talking is done in different parts of the room, and while not as loud as the bellowing of a single hoarse man, the voice is heard plainly everywhere.

CLASSIFIED ADVERTISEMENTS.

Advertisements in this column 2 cents a word, no display of any kind. Payable in advance, stamps not accepted. Count 7 words per line. Minimum, 2 lines. Heavy face type 4 cents a word. Minimum, 3 lines..

ELECTRICAL APPRATUS.

STUDY ELECTRICITY AT HOME—A complete electrical course at home, containing 30-page detail book, 220-page text-book, 200 experiments and over 100 pieces of apparatus. Price, complete, only \$5.60. Catalogue "M. E. S." explains this and other remarkable offers. Thomas M. St. John, 848 Ninth Ave., New York.

R-U INTERESTED IN THE STUDY OF ELECTRICITY? Limited offer. One Set (No. 1) Comprising 10 Leading Instruments, \$8.50. Junior Set (No. 2) 7 instruments, \$4.50. Send 2c. stamp for circulars, Palmer Electrical Instrument Co., 38th Street, z above Market, Philadelphia, Pa.

ELECTRICAL GOODS at half price. Send for catalogue. Harold Decker, La Porte, Ind.

BOYS, BUILD TELEPHONE LINES. Special bargains in second-hand and remodeled instruments. All supplies at wholesale. Send 5 cents for big catalog and sample of wonderful burning wire. Meyers Electrical House, Evansville, Wis.

WIRELESS TELEGRAPHY—New detector, guaranteed to receive messages from points hundreds of miles away. Simple and easily adjusted. Will not burn out nor lose its sensitiveness. Price, 50 cents, prepaid. (No stamps.) P. O. Box 448, New Orleans, La.

ELECTRICAL BOOKS, BLUEPRINTS, ETC.

WIRELESS TELEGRAPHY.—How to make a practical outfit cheaply. Complete details and diagrams 25c. post paid. Edwin Arnold, 102 Gelston St., Buffalo, N. Y.

FOUR TYPES of High Tension Induction Coils for Tuned Circuit Wireless Telegraphy. Set of 12 drawings, giving full data; price, \$1.00. W. C. Getz, 645 N. Fulton Ave., Baltimore, Md.

HOW TO MAKE a Chemical Rectifier. Book, 25 cents. Taylor Electrical Mfg. Co., 207 Jay St., Albany, N. Y.

WIRELESS TELEGRAPHY—How to construct and operate a wireless station at home. No experience necessary. Price, 50 cents. (No stamps.) P. O. Box 448, New Orleans, La.

ELECTRIC MOTOR CONSTRUCTION FOR AMATEURS, by C. D. Parkhurst. 75 cents. Walter D. Dunkle, 356 W. Chestnut St., Washington, Pa.

FOR SALE.

FOUR-INCH DEVINE WATER MOTOR, \$3.50; 12 Watt dynamo, \$3.50; complete outfit with lights, diagrams, etc., \$7.00. Special motor, new style. 6 Watt, drum armature, \$2.00. Any style light, 36c. C. D. Z., 131 Norwood Ave., Buffalo, N. Y.

DEVINE WATER MOTORS, \$7.00; 85 per cent efficiency; 6 volts, 6 amperes, K. & D. generators, modeled from large type generator, \$6.00; complete plant, \$13.00; just the thing for wireless outfits, electric lighting and experiments. C. W. A., 316 Woodward Ave., Buffalo, N. Y.

FOR SALE—A 1/2-hp. Electric Motor in good condition, will sell for \$15.00. J. E. Handley, Rock City Falls, N. Y.

FOR SALE—"Fisher" storage battery charger, with automatic cut-out; slightly used; perfect condition; costs \$25.00, new; will sell for \$15.00. Write. Victor E. Hawkinson, Cleburne, Kan.

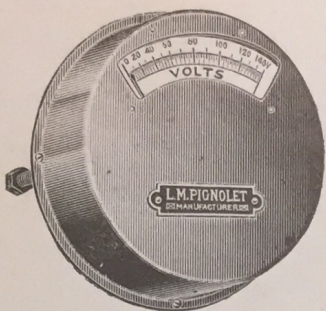

New Round Switchboard,
Volt or Ammeter,
5 inches in diameter,
1 1/2 inches deep.
Best instrument on the
market.
PRICE, \$8.00 UP

**ACCURATE
COMPACT
INEXPENSIVE**

Send for complete
catalog of portable
and switchboard
Voltmeters, Amme-
ters and Volt-Am-
meters.

L. M. PIGNOLET

82 Cortlandt Street
New York

When writing please mention "Modern Electrics."

Electric Power Motor

Sample Prepaid
for 35c.

Agents Wanted

**EMPIRE ELECTRIC
WORKS**

1063 BRIDGEPORT, CONN.

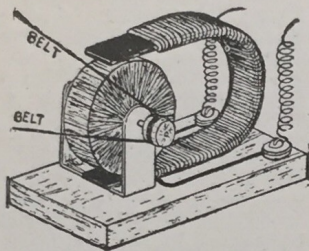

When writing please mention "Modern Electrics."

WATCH THIS SPACE



Attractive Prices

A Square Deal

Prompt Deliveries

M.E

If you want **GOOD**
goods, **GOOD** service
and **GOOD** attention
paid to you, write us.

Our trade mark shows
"what's what."

A generous catalog,
showing a line of the
best supplies in this
country will be mailed
to you promptly on
receipt of 17 cents for
postage.

Fletcher-Stanly Co.

36 FRANKFORT ST., NEW YORK

When writing please mention "Modern Electrics."

BELL TRUST SMASHED

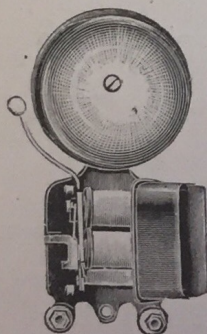

Now is the time to buy cheap.
Never again will you have such a
chance. "Electro" Iron Box
Bell, 2 1/2 inch Gong, sold three
weeks ago for 35c everywhere,

NOW 18c

This ridiculous price only good
up to May 20th. Order to-day.
Our supply is limited. First come,
first served.

To OUR FRIENDS:—If you are
wise, lay in a supply now. In
June the price will go up. You
make 50% profit on each bell.

Remember, each bell guaran-
teed or money back.

Electro Importing Co., 86-Z West Broadway, N. Y. City

NOTE NEW ADDRESS

When writing please mention "Modern Electrics."

**TESTING A MODERN ELECTRIC
LOCOMOTIVE.**

(Continued from Page 72.)

piercing blasts, grasps his current and
brake levers, and we rush upon the little
sub-station, which is situated at the inner
end of the curve and partially hidden in
trees. We are now half-way around and
move at a terrific speed when it suddenly
appears almost in our very path. On
it comes, increasing in size until we
finally dash up to it and just miss
passing barely to one side. When just
abreast of it there is a deafening roar
of the whistle and we rush past on the
far side, and, looking back, we behold
pedestrians at the crossing holding on to
their hats and one another, while to them
we rapidly grow smaller in the distance.

We have now entered the two-mile
straightaway with no crossing, change of
grade or curve within that distance. For
the whole six miles of track there are
mile, half, and quarter-mile posts with
one, two and three black hands on them
respectively. These we pass in quick
succession after leaving Wyatt's, and
when within a half-mile of the point
where the power must be shut off, a
couple of the men time our flight with
stop watches. Eleven and three-tenths
seconds is the verdict. We know that
this is for a whole quarter of a mile
and with it comes the realization that we
are covering distance at the rate of 75
miles per hour. But how easily, we
think. The objects outside have passed
us with incredible rapidity, but a
thought of such speed would vanish
when we would think of the very slight
sway and the entire absence of all for-
ward lurching.

Now we realize that the train on the
steam tracks, which we overtook and
left behind us in our mad rush, was
really a limited making up lost time,
it now flies past us at a speed that
yesterday we would have declared
being "fast!" Our short but rapid
journey is over now and as the brakes
are applied we come quietly to a stand-
still, and take a long breath and try
realize what we have experienced.

The "Mauretania" has four dynamos,
of which is capable of giving 3,260 amperes
115 volts at a speed of 1,200 revolutions
per minute. Fifty large fans are used constantly
to cool these dynamos which never stop
the entire length of a trip.

SPECIAL 30 DAY OFFER

**\$5.00
BUYS IT**

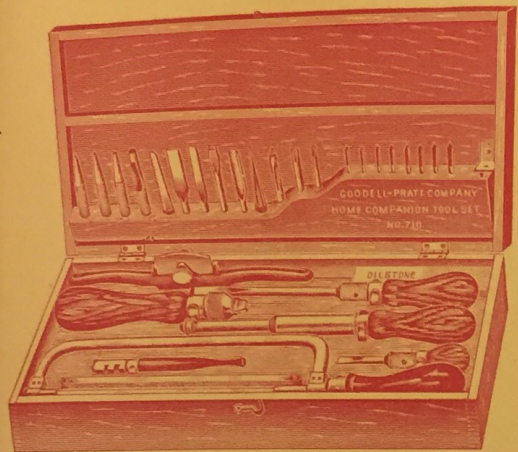

To introduce our line of Home Companion Tool Sets among the readers of "Modern Electrics" we are offering for a limited time only our

**NO. 710 SET FOR \$5.00
EXPRESSAGE PAID.**

These Tool Sets of ours comprise tools of our own manufacture, whose quality is well known, put up in handsome hardwood cases.

A complete list of the tools in each of these assortments will be found in our No. 8 Catalog which we will send free to any address.

No. 700 \$3.50

No. 711 \$8.00.

No. 712 \$10.00

No. 713 \$12.00

GOODELL-PRATT COMPANY,

86 GREENFIELD, MASS., U. S. A.

When writing please mention "Modern Electrics."

...THE...

"Electro" Static (Wimshurst) Machine

Guaranteed to generate in any kind of weather, no matter, foggy or rainy. The first machine ever constructed which can truthfully claim this. We absolutely guarantee a fat, powerful 3-in. spark from our new machine. It is used successfully to operate Geissler and X-Ray tubes, charging the biggest Leyden jars, firing powder, working wireless sets for short distances.

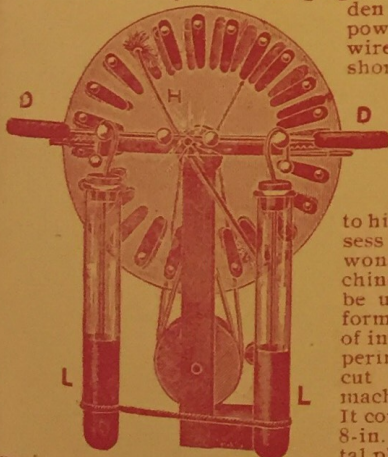

raising a person's hair, etc. Anybody interested in electricity owes it to himself to possess one of these wonderful machines which can be used to perform thousands of interesting experiments. Our cut shows the machine plainly. It comprises two 8-in. glass crystal plates revolving

in opposite directions, two adjustable oscillator and discharging rods and balls D, collectors H and one iron clamp to fasten body to table. Size over all 11x14 in. Weight boxed 8 lbs. Nothing to wear out, no batteries, no trouble, simply turn the crank, the machine does the rest. **Price, complete boxed, \$3.75.** If you haven't got our 100 page catalogue No. 4, send 2c stamp for it; contains 100 experiments.

Electro Importing Co.

86z West Broadway, New York

"Everything for the Experimenter"

When writing please mention "Modern Electrics."

SOMETHING NEW

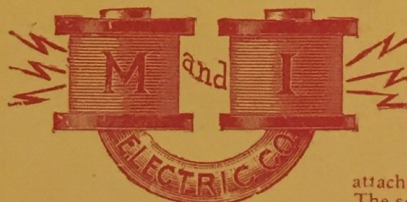

Our Canoe and Bicycle Search Light is a wonder. Throws a powerful beam of brilliant white light for a distance of 100 feet. Fits any bicycle, and can be attached to any vehicle.

The search light is movable and finely nickelplated. Works with ordinary dry cells or small storage battery. Comes with Tantalum lamp, using 1/2 ampere. When ordering state voltage lamp is to be used on.

PRICE, COMPLETE, \$1.50 BY MAIL

Headquarters for scientific electrical goods. New apparatus made to order. Inventor's materials. Can send pamphlet of any electrical apparatus on receipt of 2 cent stamp.

If we havn't got it, it isn't made.

Manufacturers' and Inventors' Electric Co.

82 1/2 NASSAU STREET, NEW YORK

When writing please mention "Modern Electrics."



**A Sensational Novelty.
Will Last a Lifetime
THE IMPROVED FLAMING
POCKET LIGHTER.**

Patented July 9, 1907, and Sept. 10, 1907
Infringers cautioned.

Every smoker wants it. Will light in windy weather. Better than matches. A little deodorized wood alcohol once in a while does the trick. Nothing to wear out. Sample mailed upon receipt of 55c. Special prices to dealers in dozen or gross lots. If you wish to make big money this summer write at once to

The Auto Igniter Co., 1947 B'dway, N. Y. City

When writing please mention "Modern Electrics."

Send for it Send for it Send for it Send for it Send for it Send for it
 Send for it Send for it Send for it Send for it Send for it Send for it
 Send for it Send for it Send for it Send for it Send for it Send for it
 Send for it Send for it Send for it Send for it Send for it Send for it
 Send for it Send for it Send for it Send for it Send for it Send for it
 Send for it Send for it Send for it Send for it Send for it Send for it
 Send for it Send for it Send for it Send for it Send for it Send for it
 Send for it Send for it Send for it Send for it Send for it Send for it
 Send for it Send for it Send for it Send for it Send for it Send for it
 Send for it Send for it Send for it Send for it Send for it Send for it
 Send for it Send for it Send for it Send for it Send for it Send for it
 Send for it Send for it Send for it Send for it Send for it Send for it
 Send for it Send for it Send for it Send for it Send for it Send for it
 Send for it Send for it Send for it Send for it Send for it Send for it
 Send for it Send for it Send for it Send for it Send for it Send for it
 Send for it Send for it Send for it Send for it Send for it Send for it
 Send for it Send for it Send for it Send for it Send for it Send for it
 Send for it Send for it Send for it Send for it Send for it Send for it
 Send for it Send for it Send for it Send for it Send for it Send for it
 Send for it Send for it Send for it Send for it Send for it Send for it
 Send for it Send for it Send for it Send for it Send for it Send for it



When writing please mention "Modern Electricians."

A School Within Itself

designing, care and operation of a dynamo or motor and I chapter on electric automobiles, outlining their construction, care and operation, and all about storage batteries and how to handle them.

There are XX chapters in all XIX carrying you from the fundamental principles of electricity on through the various branches to a point where the careful student comprehends the complete operation of electric automobiles, outlining their construction, care and to the point. After a student studies a subject, he is questioned on that subject in such a manner as to bring clearly to his mind the points he needs to know regarding same. A DICTIONARY in back of book will enable him to learn the meaning of any electrical word, term or phrase used in this book, as well as hundreds of others in common use. All required tables necessary in the study are in it.

CHAPTER TABLE OF SUBJECTS:

- I Wiring
- II Electric Batteries, Electric Plating
- III Magnetism
- IV The Magnetic Circuit
- V Magnetic Traction
- VI Magnetic Leakage
- VII Energy in Electric Circuit
- VIII Calculation of Size of Wire for Magnetizing Coils
- IX Calculation of E. M. F.'s in Electric Machines
- X Counter E. M. F.
- XI Hysteresis and Eddy Currents
- XII Armature Reaction
- XIII Sparking
- XIV Winding of Dynamos and Motors
- XV Proper Method of Connecting Dynamos and Motors--Self Excitation and others

\$2.00 PER COPY—FOURTH EDITION—16,000 COPIES SOLD.

The offer we make of refunding money if book is not satisfactory upon examination is AN UNUSUAL ONE in connection with the sale of a book. But we have no fear of its return. Your decision will be what thousands of others have been. Money would not buy it if it could not be duplicated. We could print testimonials by hundreds. It is best to order and be your own judge of its merits.

**CLEVELAND ARMATURE WORKS
12 CLEVELAND, OHIO**

AMERICA'S GREATEST REPAIR WORKS.
ARMATURES AND FIELDS WOUND. COMMUTATORS FILLED.

When writing please mention "Modern Electricians."